

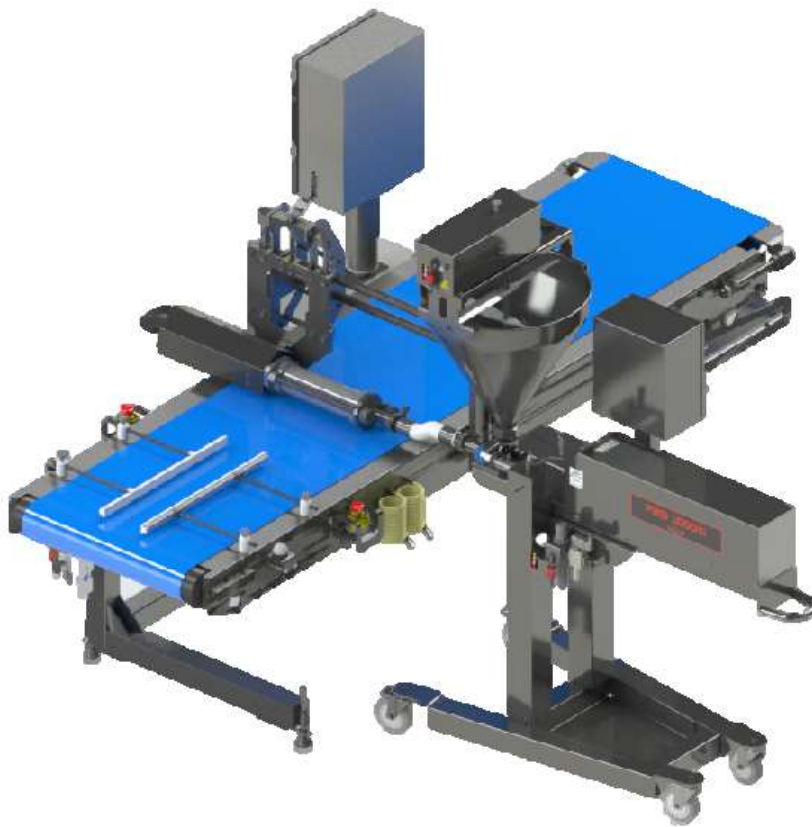

# SERVO MID-FILL STATION



**INSTRUCTIONS AND  
SPARE PARTS**

15/04/2019 Ver 0  
Serial number SBC-088343-005-0  
Translation from the original instructions

# Table of Contents

<b>TABLE OF CONTENTS</b> .....	<b>2</b>
<b>SAFETY GUIDE</b> .....	<b>5</b>
SYMBOL DEFINITIONS.....	5
EQUIPMENT INTEGRATION.....	6
<b>SAFETY AWARENESS</b> .....	<b>7</b>
<b>INTRODUCTION</b> .....	<b>10</b>
<b>CONTACTING UNIFILLER SYSTEMS INC</b> .....	<b>10</b>
<b>MACHINE DESCRIPTION</b> .....	<b>11</b>
OPERATIONAL MODES.....	12
<b>RECEIVING AND UNPACKING</b> .....	<b>13</b>
<b>SERIAL NUMBER LOCATION</b> .....	<b>13</b>
<b>POWER REQUIREMENTS</b> .....	<b>14</b>
COMPRESSED AIR REQUIREMENTS.....	14
ELECTRICAL POWER REQUIREMENTS.....	14
<b>INITIAL MACHINE SETUP</b> .....	<b>15</b>
MACHINE.....	15
<b>OPERATING THE MACHINE</b> .....	<b>18</b>
INTRODUCTION.....	18
SEQUENCE OF OPERATION.....	20
<b>CONTROLS</b> .....	<b>21</b>
PRODUCTION SETUP AND OPERATOR ADJUSTMENTS.....	21
ACCESS LEVELS AND DEFAULT PASSWORDS.....	21
CONTROL BOX LAYOUT.....	22
STARTING AND STOPPING THE MACHINE.....	23
<i>Normal starting and stopping</i> .....	23
<i>Emergency Stop</i> .....	24
<b>OPERATOR SCREEN OVERVIEW</b> .....	<b>25</b>
GENERAL DESCRIPTION AND OPERATION OF THE OPERATOR SCREENS.....	26
<i>Screen Navigation</i> .....	26
HELP FILES.....	26
MAIN SCREEN.....	27
MAIN SCREEN CONTINUED.....	28
STATION #1 DEPOSITOR.....	29
STATION #1 PRO1000SI.....	30
STATION #1 SERVO PROFILE.....	32
STATION #1 PRO1000SI PROFILE.....	33
STATION #1 REFERENCES SCREEN.....	34
STATISTICS SCREEN.....	35
RECIPE SCREEN.....	36
MODE SCREEN.....	37
SYSTEM SCREEN.....	38
ALARM HISTORY SCREEN.....	39
TECHNICAL SCREEN.....	40
NEW PASSWORD SCREEN.....	42

CLEAN SCREEN .....	43
LOGIN SCREEN .....	44
<i>Diagnostics Screen</i> .....	45
<i>Diagnostics – Inputs Screens</i> .....	46
<i>Diagnostics – Outputs Screens</i> .....	47
<i>Diagnostics - UNICAN Communications Screen</i> .....	48
<i>Diagnostics - CANOPEN Communications Screen</i> .....	49
<i>Diagnostics - ETHERNET Communications Screen</i> .....	50
<b>TROUBLESHOOTING</b> .....	<b>51</b>
<b>DISASSEMBLY, CLEANING AND SANITIZING</b> .....	<b>57</b>
GENERAL INSTRUCTIONS .....	58
DISASSEMBLING .....	59
<b>CLEANING AND SANITIZING</b> .....	<b>64</b>
CLEANING AND SANITIZING .....	65
<i>Re Assembly</i> .....	66
O-RING AND SEALS CARE .....	67
<i>O-Ring and Seals Part Numbers</i> .....	67
<b>TECHNICAL SECTION</b> .....	<b>68</b>
RECIPE BACKUP AND RESTORE .....	68
<i>Backing Up Recipes to the SD Card</i> .....	68
<i>Restoring all Recipes to the Machine</i> .....	69
<i>SD Card Recipe Files</i> .....	69
BELT ADJUSTMENT .....	70
<b>PREVENTATIVE MAINTENANCE</b> .....	<b>71</b>
MACHINE OWNER / OPERATOR CARE .....	71
SPARE PARTS KITS .....	71
DELUXE SPARE PARTS KIT .....	71
<i>Weekly</i> .....	72
<i>3 Months</i> .....	72
3 YEARS, 6000 HOURS OR 7 MILLION CYCLES .....	72
<b>EXLAR LINEAR SERVO DRIVE MAINTENANCE</b> .....	<b>73</b>
ROLLER SCREW LUBRICATION GREASE REPLACEMENT .....	73
<b>TROUBLESHOOTING</b> .....	<b>74</b>
SPARE PARTS .....	75
RECOMMENDED SPARE PARTS LIST .....	75
<b>MECHANICAL SPARE PARTS</b> .....	<b>76</b>
<b>CONTROL SYSTEM SPARE PARTS</b> .....	<b>115</b>
<b>PNEUMATIC SCHEMATICS</b> .....	<b>116</b>
PNEUMATIC COMPONENTS .....	117
<b>ELECTRICAL SCHEMATICS</b> .....	<b>118</b>

# **SAFETY INSTRUCTIONS AND WARNINGS**



These safety instructions must be read prior to operating, sanitizing or servicing the equipment.

All machines have a risk of personal injury wherever moving parts are involved in their operation. UNIFILLER has taken all possible precautions to reduce and wherever possible eliminate the dangers associated with moving parts. Having all operators/maintenance staff of this equipment read and abide by the instructions in this manual will further reduce the risk of personal injury. All users must familiarize themselves with the warning decals located around the machinery.

This equipment is not to be used by persons (including children) with reduced physical, sensory or mental capabilities, or lack of experience and knowledge, unless they have been given supervision or instruction.

Caution - the air lines on this machine are under high pressure. Severe injury could result if tampering or adjustments are made by non-qualified personal.

Before cleaning, dismantling, or servicing the machine, turn air off and bleed pressure from the air supply prior to disconnecting airline. Isolate any other power sources, and then lock them out. Refer to Maintenance section

Safety guards or devices must not be removed or disabled by any personnel other than when locked out for service maintenance by a technician.

Keep fingers and hands away from all pinch points, mechanical moving parts, including the hopper inlet and deposit nozzle outlet.

Do not run product or water, with temperatures exceeding 140°F, (60°C), through the machine. For product temperatures that exceed 140°F, (60°C) up to 180°F, (82°C), please use HOT changeover parts on the machine. Contact Unifiller Systems for details.

Operating air pressure should not be adjusted to exceed 80 P.S.I. (551 kPa /5.52 Bar) on the air regulator / water filter pressure gauge.

Before use, fully sanitize the machine. Dismantle and lubricate all the seals as per cleaning/sanitizing instructions in this manual after each use.

Before use ensure that the locks on the wheels are engaged.

For servicing or technical support please contact UNIFILLER directly or one of its authorized suppliers or dealers.



Unifiller Systems recommends the use of approved personal protection equipment when using this equipment.

# Safety Guide

All machines have a risk of personal injury wherever moving parts are involved in their operation. UNIFILLER has taken all possible precautions to reduce, and wherever possible, eliminate the dangers associated with moving parts. Having all operators/maintenance staff of this equipment read and abide by the instructions in this manual will further reduce the risk of personal injury.

## All employees assigned to operate the equipment must:



### WARNING



Read the safety instructions prior to operating, sanitizing or servicing the equipment. After reading, store the manual in a safe place for further reference and training

Familiarize themselves with the warning decals located on and around the machinery

Be properly trained and made aware of all potential operating hazards and risks associated with the equipment

## Symbol Definitions

	<p><b>WARNING</b></p>	<p>This safety alert symbol indicates a situation that can result in personal injury or property damage.</p>
	<p><b>IMPORTANT</b></p>	<p>This indicates a stop function prior to proceeding.</p>
	<p><b>WARNING</b></p>	<p>This symbol indicates a situation that can result in hands being crushed or cut.</p>
	<p><b>WARNING</b></p>	<p>This symbol indicates a situation that can result in hands being crushed from nozzle diving motion.</p>
	<p><b>WARNING</b></p>	<p>This symbol indicates a situation that can result in fingers being severed from nozzle rotational motion.</p>

	<p><b>WARNING</b></p>	<p>This symbol indicates a situation that can result in fingers being crushed from piston actuation.</p>
	<p><b>IMPORTANT</b></p>	<p>Read and understand the manual for this machine before use.</p>
	<p><b>IMPORTANT</b></p>	<p>Read and understand the manual for this machine before use.</p>

## Equipment Integration

This equipment is sold as a standalone unit and may be integrated into third party equipment as part of a larger automated production system.



Depending on the system configuration, environment, layout, production procedures, and level of personnel training, additional hazards may become present that are not outlined in this operational manual.

Unifiller System strongly recommends that customers conduct an onsite risk assessments to ensure the safety of all personnel and adherence to local safety regulations as additional guarding/safety procedures may be necessary.

# Safety Awareness

- Do not operate machine without the product cylinder installed. If it becomes necessary to operate the machine without a product cylinder in place, caution must be observed that you do not place any body parts near the operating parts of the machine, or pinch points.



- The indicated areas shown are potential pinch points. Do not place fingers near or in these areas.

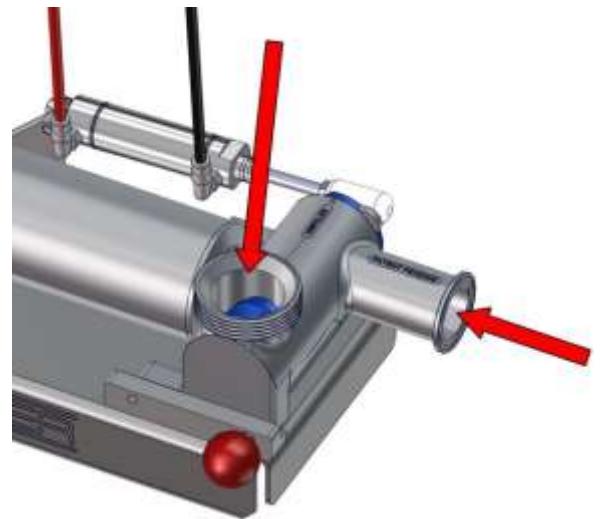

- When closing the top cover be cautious that fingers do not get pinched.

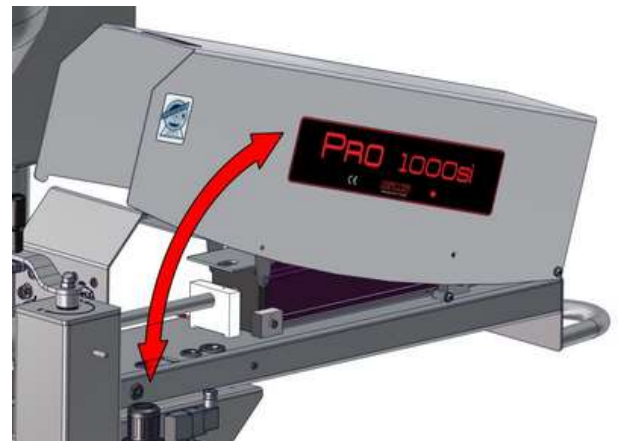



- During operation of the machine, do not remove the red safety pin as the hopper and product cylinder may fall off, if action occurs during mid-cycle.



- Use caution when starting the machine as it may operate and move parts to their “Home” position, if it was stopped during its cycle due to a power outage.
- Do not attempt to remove the hopper from the equipment when full of product. Always empty the hopper of product prior to removal.





- Do not put your finger or other body parts between the belt and the roller



- Do not put your fingers or other body parts in close proximity of the nozzle opening

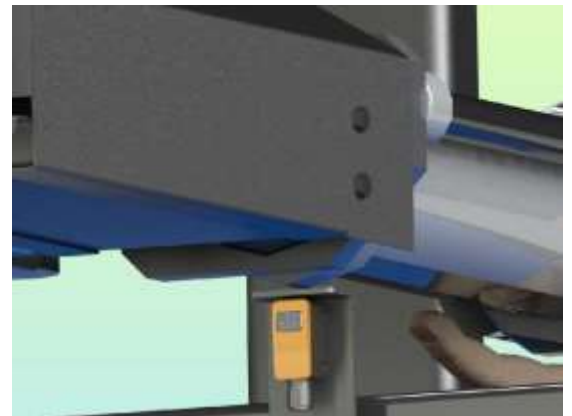

## **Introduction**

Thank you for purchasing Unifiller Systems Inc equipment. We are sure you will get years of trouble free use and excellent productivity from your new investment.

Please take a few minutes to read this manual and familiarize yourself with the layout of the controls, and the set up and operating procedure.

If you have any questions regarding the setting up, or operation of your equipment please contact us.

## **Contacting Unifiller Systems Inc**

Manufacturer

Unifiller Systems Inc.  
7621 Macdonald Road  
Delta, B.C.  
V4G 1N3

Telephone

Main: 604-940-2233  
Toll Free: 1-888-733-8444

Fax : 604-677-5844

Email: [parts@unifiller.com](mailto:parts@unifiller.com) or [service@unifiller.com](mailto:service@unifiller.com)

OR

Contact your local authorized Unifiller Systems Inc. dealer.

Please see our website for dealer contact information at [www.unifiller.com](http://www.unifiller.com)

Please remember to supply your company name, telephone number, email and a contact name when ordering parts.

# Machine Description

The Servo Mid-Fill station has been designed to deposit product (icing) on round cakes.

The station consists of the following machines:

- **Conveyor (with Nozzle)** - driving the system – transferring the cakes from the infeed through the depositing station all the way to the outfeed
- **Depositor (PRO1000si)** – ‘slave’ (driven) machine – functioning as precise product pump to achieve round shaped icing layers.

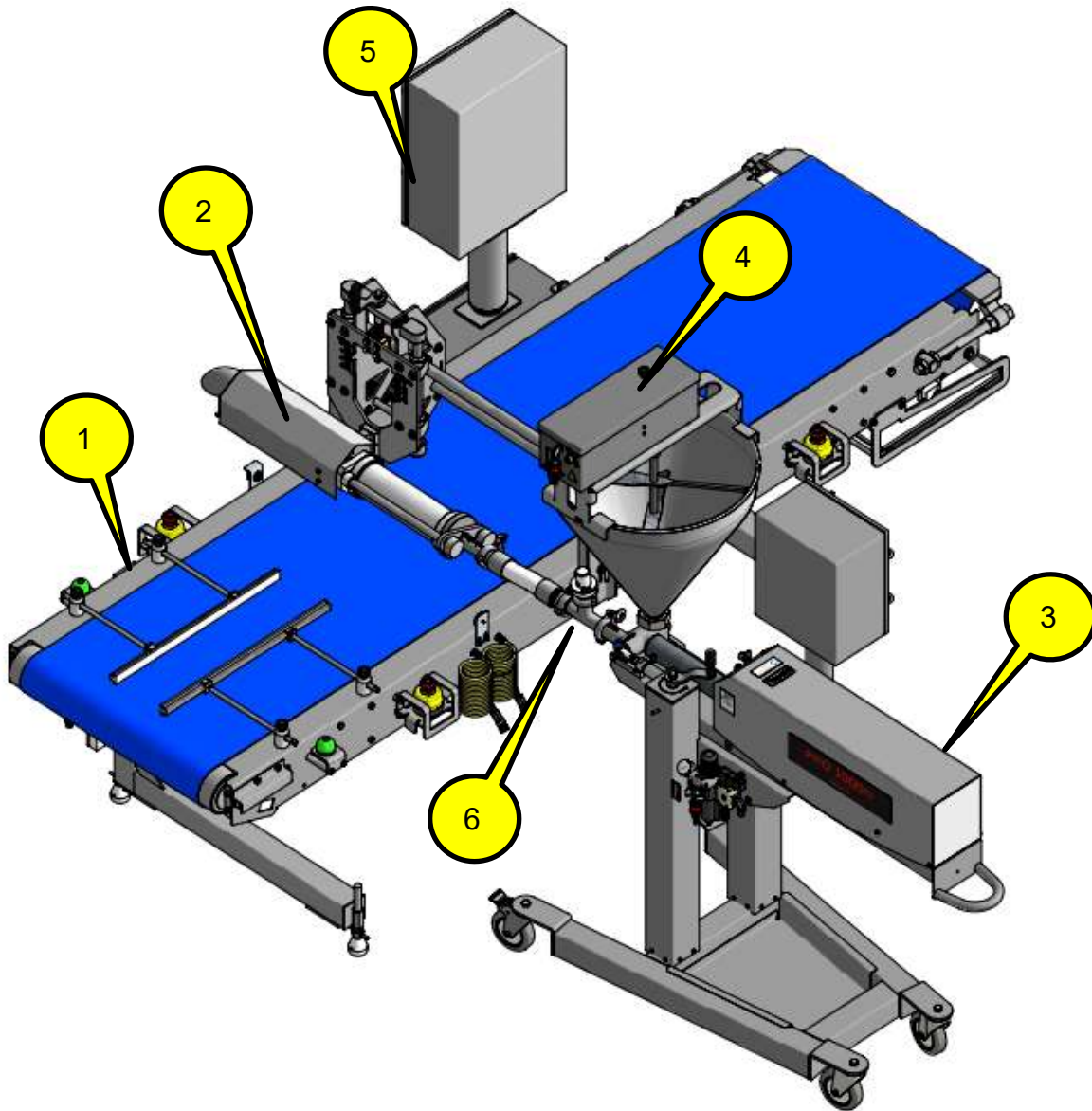

### Main components

1. Conveyor	2. Servo Nozzle	3. PRO1000si*	4. Stirrer**	5. Control Box	6. Relief valve
-------------	-----------------	---------------	--------------	----------------	-----------------

\* PRO1000si can be used as a stand-alone machine. Before using the machine outside of this system please read and follow the manual located in the spare parts box of PRO1000si.

\*\* For parts related to Pneumatic Stirrer please refer to manual supplied with the equipment.

Machine dedicated to this conveyor is labeled with 'mid-fill' on top of the cover to avoid confusion with other machines of the same type.

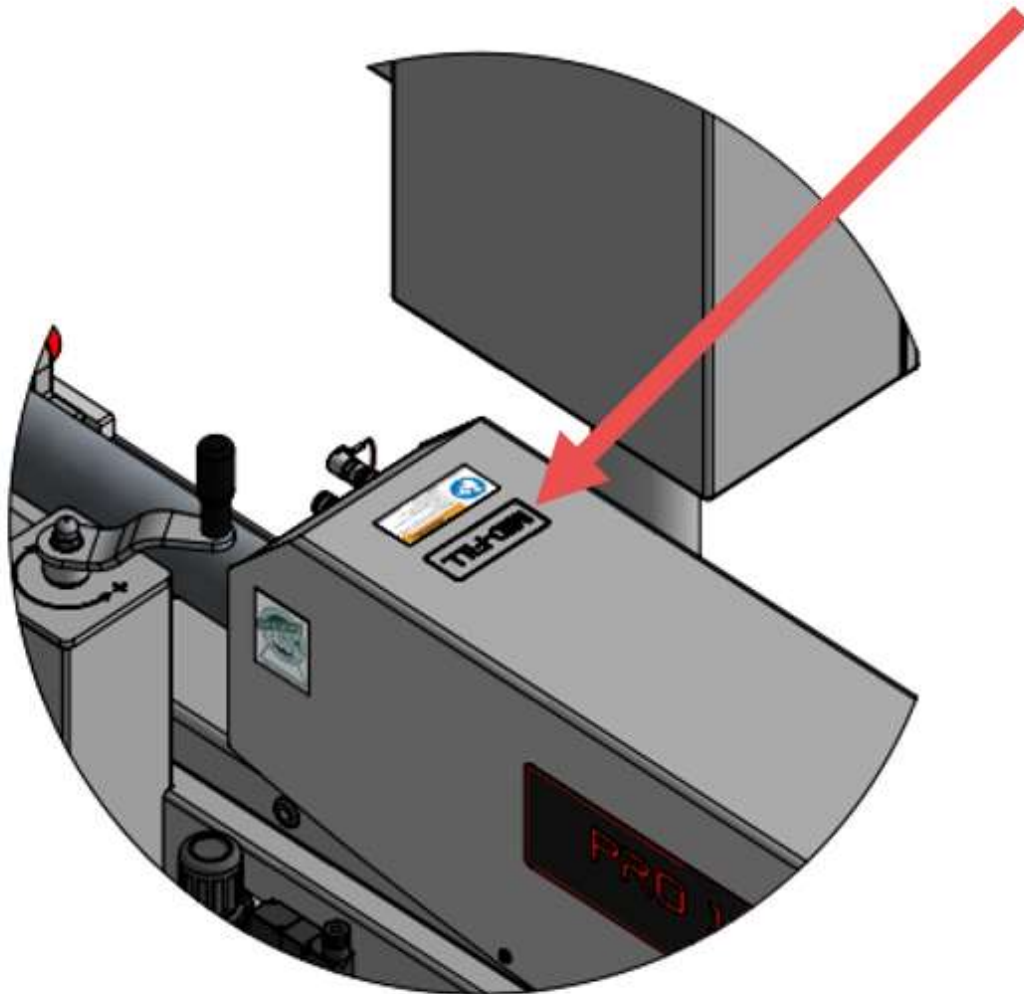

## Operational Modes

This machine will only run in continuous mode.

## **Receiving and Unpacking**

Remove all packaging and shipping materials from the crate.

Remove the spare parts kit from the shipping box. Store it in a safe storage area close by the machine for easy access.

## **Serial Number Location**

The serial number positively identifies your specific machine.

Quote this number for technical support or when ordering spare parts.

It is located at the position shown in the picture beside.

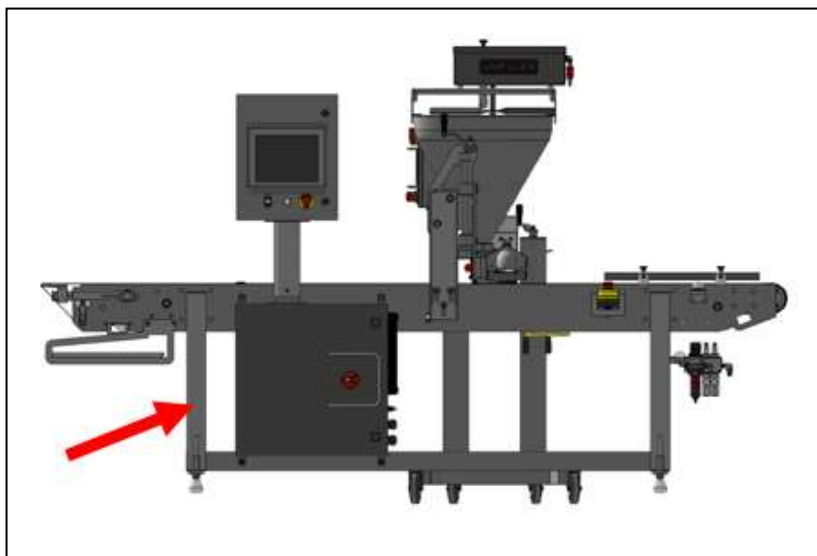

# Power Requirements

## Compressed Air Requirements

- It is recommended that the compressed air supplied to the depositor be run through an efficient air dryer before connecting to the machine. Please contact Unifiller Systems Inc for details.
- Use an airline with a minimum inside diameter of 3/8" (10mm)
- Optimum performance is achieved by setting the air pressure gauge on the machine to 80 P.S.I. (6 Bar) at rest, and at least 70 P.S.I. (5 Bar) while cycling. If not, check that the air supply to the machine is set to the correct pressure and not restricted by undersized fittings or hoses.

Connect your supply air hose that comes from your compressor (not supplied) to the quick connector (1)

Set the air pressure gauge on the machine to 80 P.S.I. (6 Bar) by pulling up the knob (2), adjusting the air pressure, and then pushing the knob down to lock it.

The air supply (On/Off) is controlled by the Red slide valve (1).

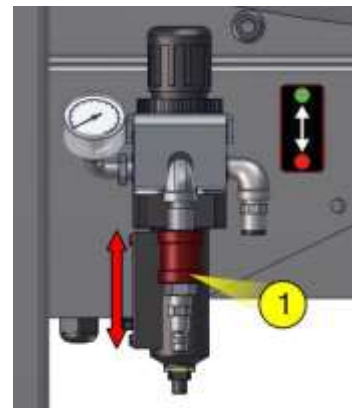
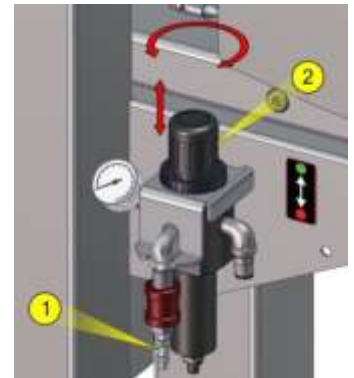

## Electrical Power Requirements

Machine	Requirement
Servo Nozzle Station	240VAC 1 phase, 15A
PRO1000si	240VAC 1 phase, 15A

# Initial Machine Setup

Before commencing the production, ensure the machines are assembled correctly with seals in place, and that the correct depositing outlet attachment is fitted and all clamps are tightened.

## Machine

1. Make sure the machine is fully assembled and all seals are in place (see section 'Initial Machine Setup').
2. Adjust the guide rails and the bridge so the opening of the nozzle and the guiderails are aligned.

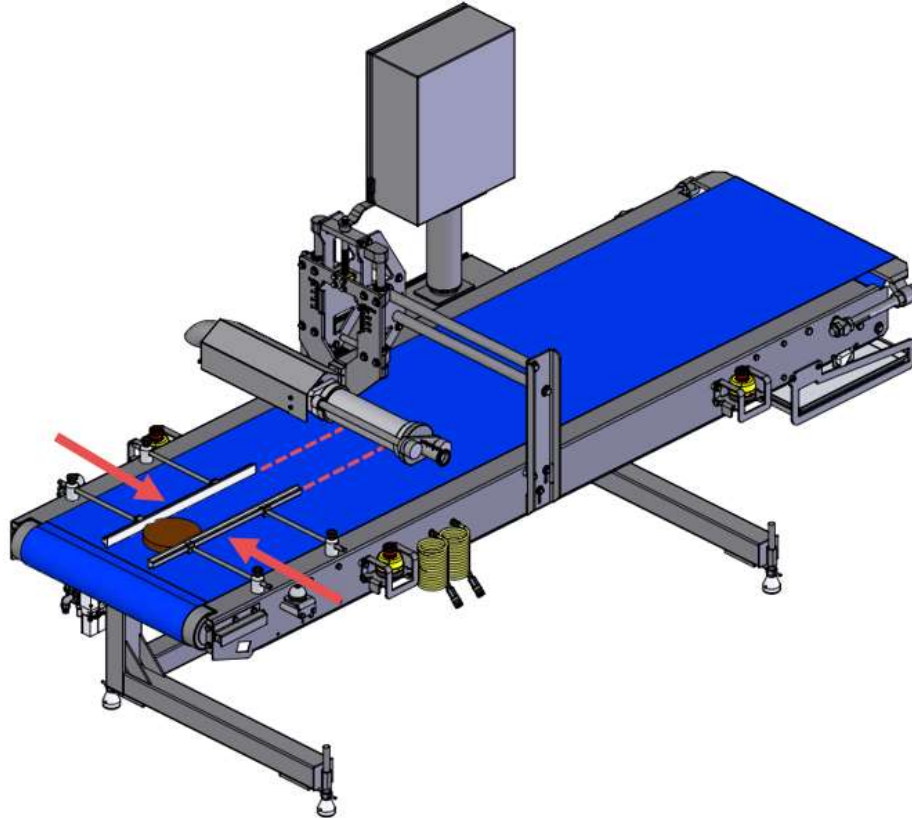

3. If lateral adjustment of the nozzle is necessary use allen key to loosen up the set collars located on the sides of the bridge. Push the bridge to the desired location and tighten the screw to fix the bridge in place.

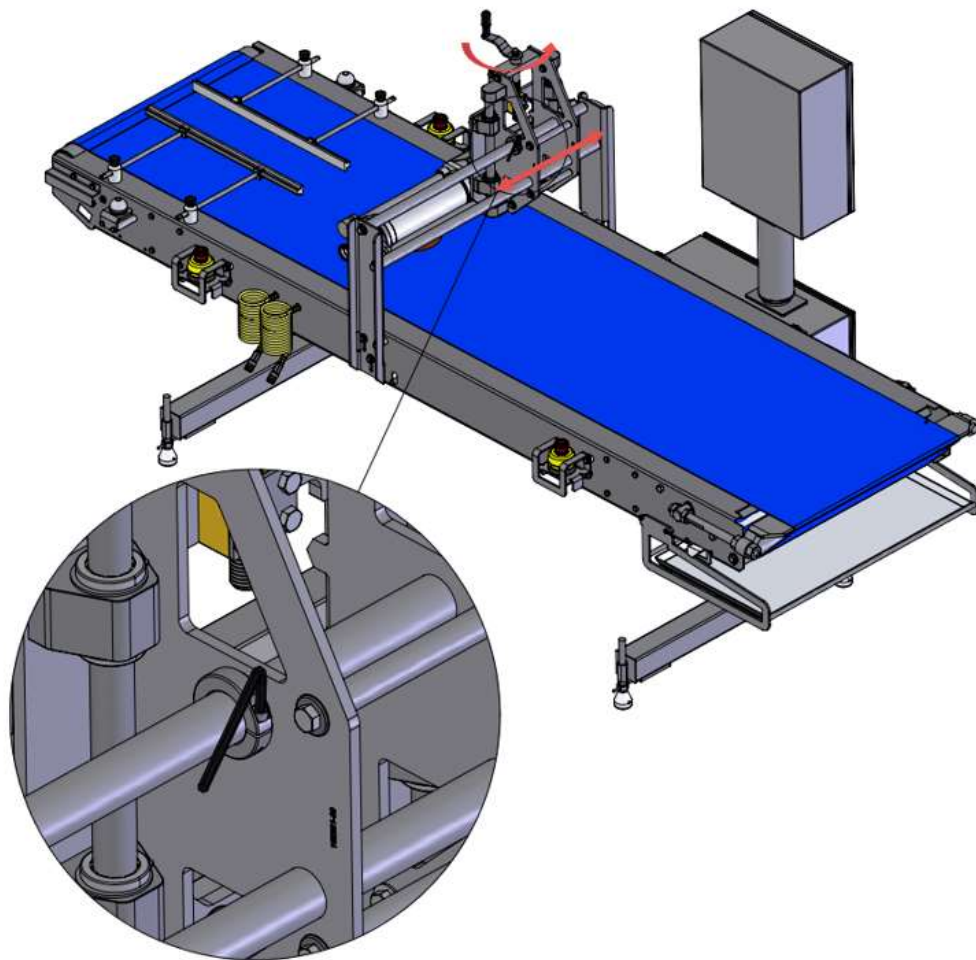

4. Adjust the height of the nozzle. Consider these when adjusting it to the right height:
  - If the nozzle is set too high the product may stretch causing the icing to break (creating air pockets)
  - If the nozzle is too low it will smear the icing causing inconstant finish.
5. Connect PRO1000si depositor communication cable
6. Connect the product hose
7. Connect the air hose to the conveyor
8. Assemble the Stirrer on the hopper
9. Connect the air hoses hanging from the deck to the PRO1000si and the Pneumatic Stirrer

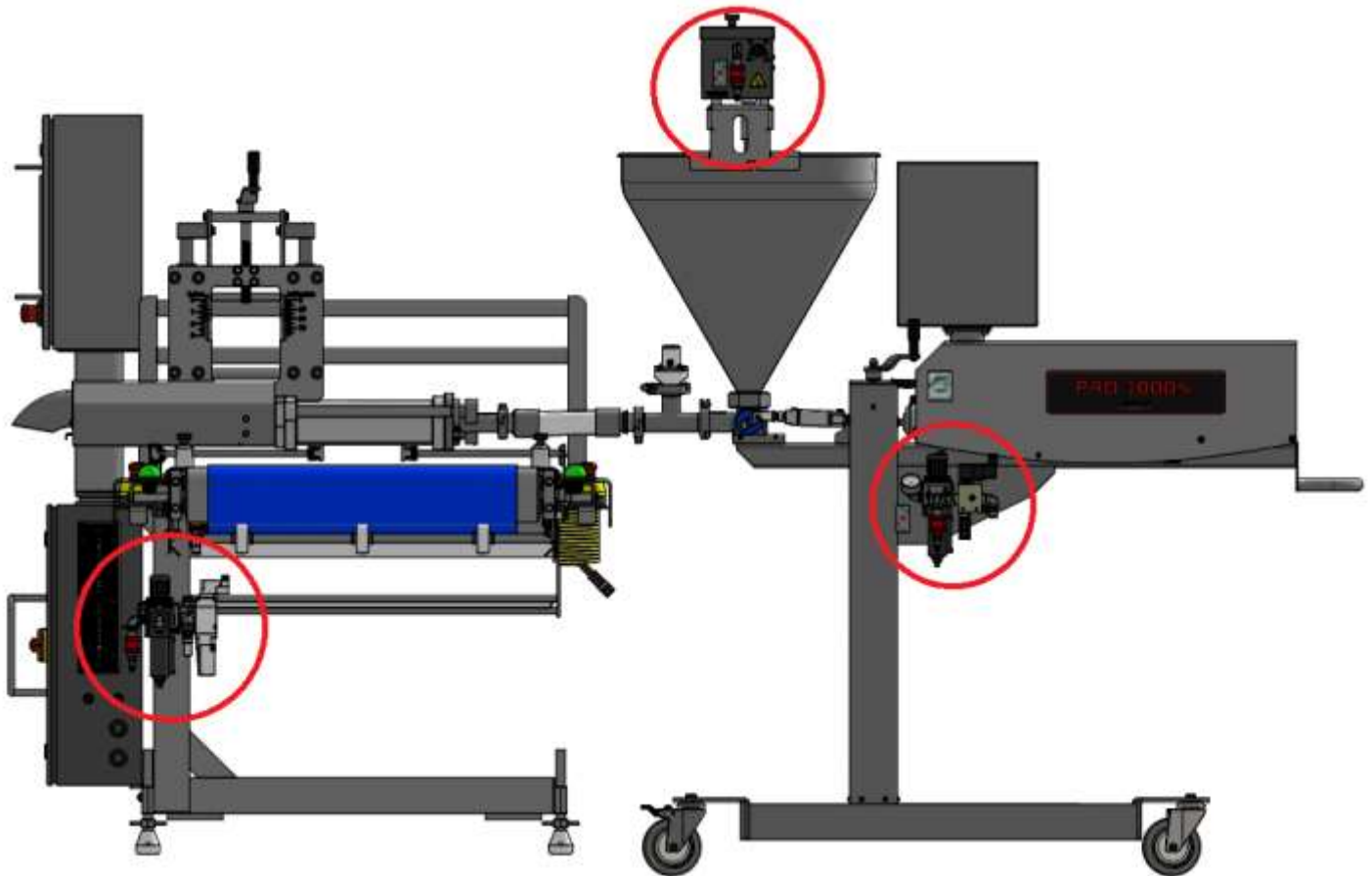

10. Switch the air on by moving the valve (1) upwards on the conveyor, PRO1000si (location of valves indicated with red circle in picture above).



11. Fill the hopper with product and purge the nozzle (see 'Controls' section).
12. Switch the Pneumatic stirrer on by opening the valve (see step 10 for reference)
13. Adjust parameters as described in the following sections to achieve desired look for production

# Operating the Machine

## Introduction

If the cakes are assembled (stacked) automatically, the cakes must be placed on the conveyor in the right sequence. This allows to ensure that the cake layer traveling on the cardboard is always placed on the bottom of the stack (see attached picture).

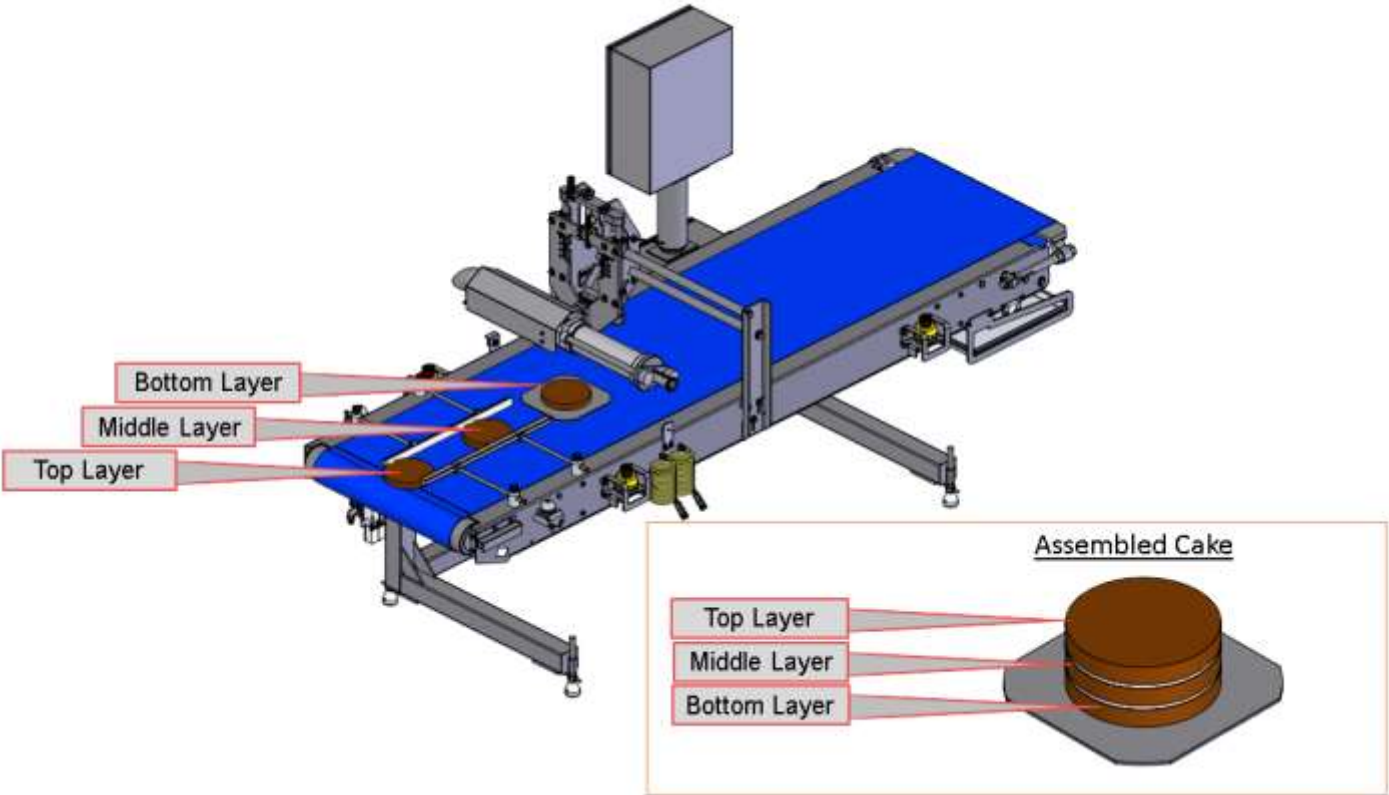

It is crucial for productivity to place the cake layers at the right moment. To help place the cakes on the conveyor in the correct sequence and at the right time two pacing lights have been placed on each side of the conveyor.

The pacing lights flash in the following sequence:

Light Colour	Interpretation
Yellow	Place cake layer on cardboard on the conveyor
Green	Place cake layer (no cardboard).

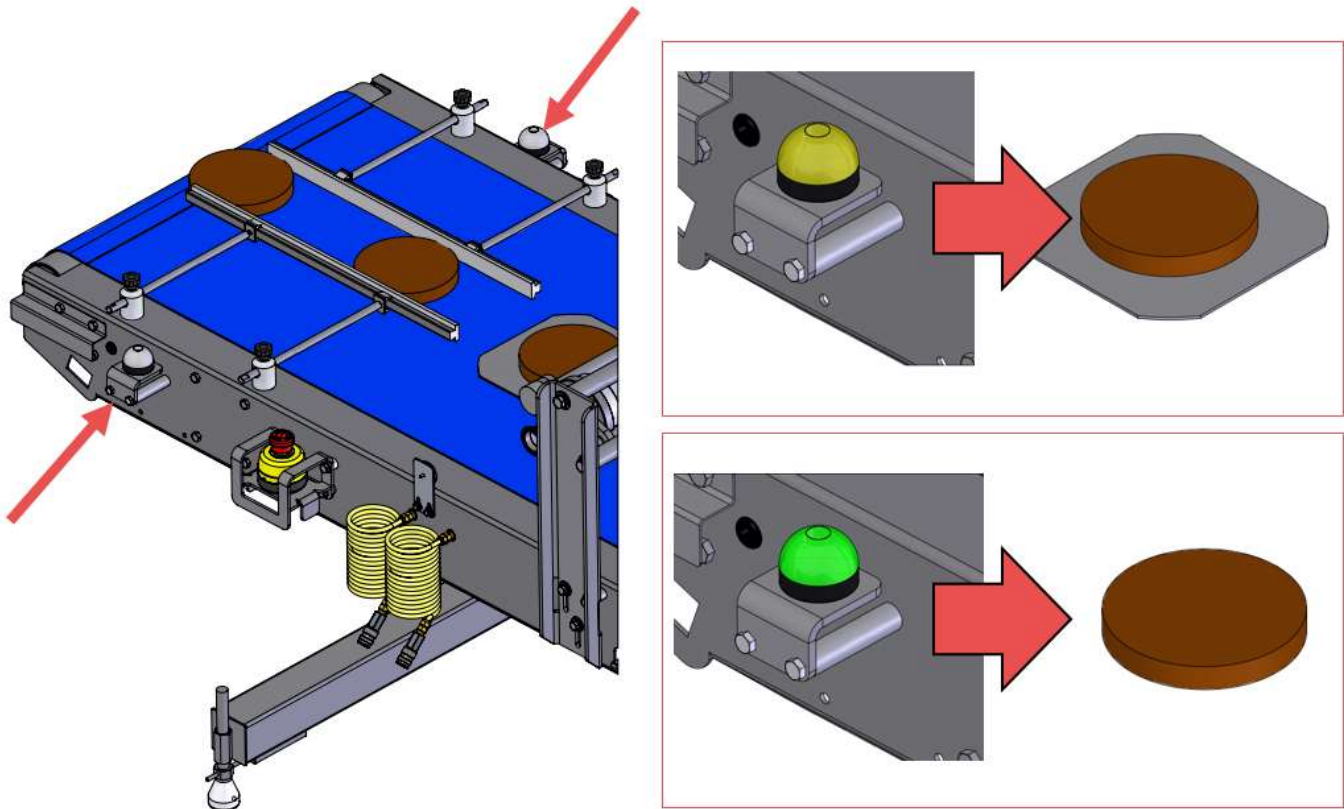

The count is automatically reset after one cycle (1 fully assembled cake),

Note that the number of assembled layers can be modified in the control system of the machine.

If the flow is interrupted (cake layer not placed on the conveyor or deposit not correct) the count can be reset manually by tapping the touch button. The cake that has been interrupted must be removed from the line by the operator to ensure no jam-ups occur.

## Sequence of Operation

1. The count is reset by tapping the touch button
2. The cake is placed on the conveyor
3. The following layers are placed on the conveyor as the pacing light flashes
4. The sensor detects the presence of the cake layer and triggers the deposit
5. Steps 3 & 4 are repeated

# Controls

## Production Setup and Operator Adjustments

This section describes in more detail the parameters and adjustments required to setup and operate the machine.

## Access Levels and Default Passwords

The operator interfaces are designed with three access levels for customers as listed below.

Access Level	Rights	Default Password	Notes
Operator	<ul style="list-style-type: none"><li>• Load recipes</li><li>• Change machine Station Parameters</li><li>• Access statistics</li><li>• Access to wash function</li><li>• Reset cycle, cake, shift and product counters</li></ul>	None	Operators can load recipes and change settings throughout production, but are not allowed to save and overwrite recipes
Supervisor	<ul style="list-style-type: none"><li>• Save Recipes</li><li>• Change System Parameters</li><li>• Change functional modes</li><li>• Change production rate on indexed systems</li></ul>	2	Supervisors have the ability to save recipes
Technician	<ul style="list-style-type: none"><li>• Access to Technical Screen and Diagnostic screens</li><li>• Change access level Passwords</li></ul>	2233	Technicians have access to technical sections and can change passwords for the Supervisor and Technician access levels

# Control Box Layout

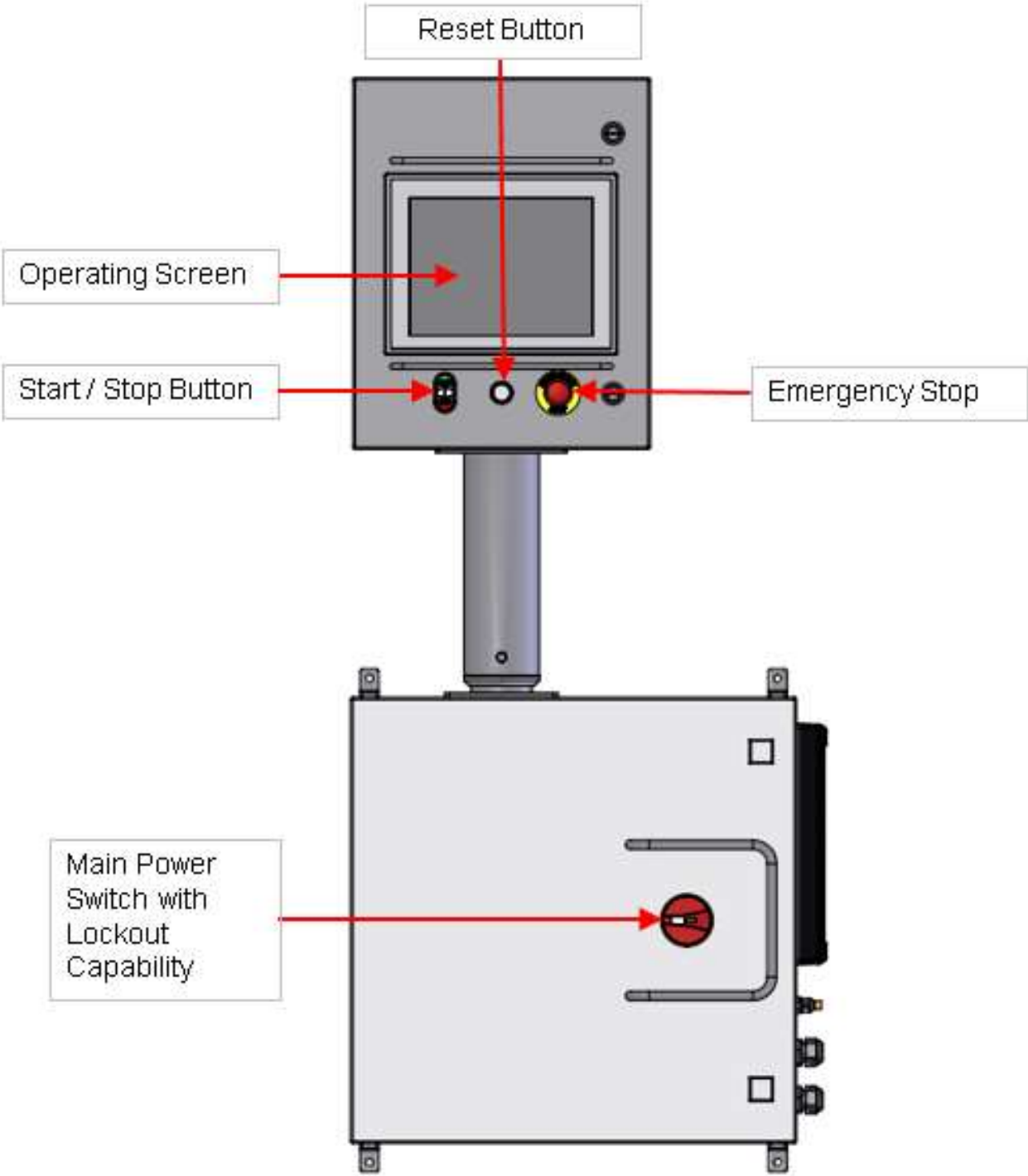

## Starting and Stopping the Machine

### Normal starting and stopping

This machine is equipped with a Unitronics controller with a touch screen interface. Below the touch screen are three buttons, start, stop, and emergency stop.

- Press the green start button to start the machine
- Press the red button to stop the machine

The machine will come to a controlled stop to avoid damaging or losing product. For this reason the machine may continue to operate until depositors or stations have finished their cycles and / or the conveyor has finished an index cycle.

## Emergency Stop

Emergency stops are located on the control panel and on the conveyor. When they are triggered, they require a manual reset. To reset an Emergency stop, pull the E-Stop button out. To reset “rope” E-stops, rotate the blue reset switch.

When connected into a larger system the e-stop will automatically stop all other machines in the line. ALL machines in the system must be reset (by pressing the flashing reset button) in order to continue production.

The emergency stop is intended to be used only in case of personal injury. The machine will stop immediately. Product damage or loss may occur.

Your system may contain one of the following types of E-stop devices:

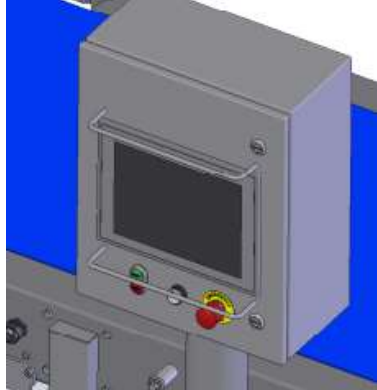
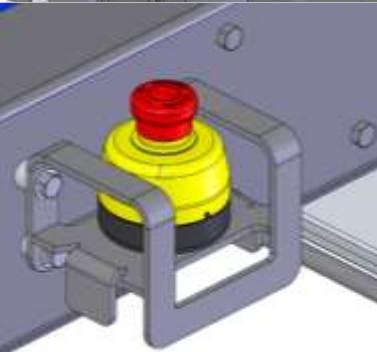
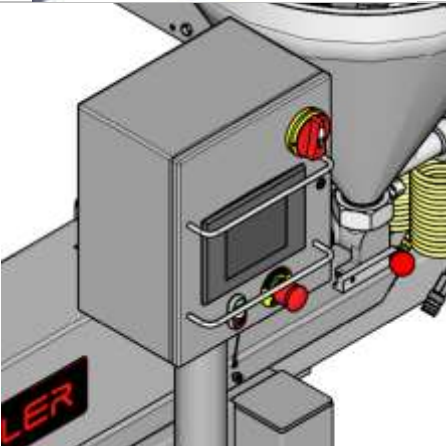
Location	Quantity	Reset	Visualization
Control Box	1	Rotate clockwise and pull out	
Conveyor	3	Pull button out	
Depositor	1	Rotate clockwise and pull out	

## **Operator Screen Overview**



The operator screen is a touch sensitive screen. While it is industrial duty, avoid touching it with sharp objects or hitting it with direct water spray during cleaning.

To change parameter values, an on-screen keyboard will pop up.

## General Description and Operation of the Operator Screens

This section describes the overall hierarchic layout of the operator screens and the general operation of the operator screen.

### Screen Navigation

These buttons are located in the bottom corners of every screen and are used to navigate through the different operator screens.

Item	Function
BACK Button	This button returns to the previous screen.
NEXT Button	This button proceeds to the next screen when available.

### Help Files

Help Files are accessed by touching any parameter name. These files allow the operator to get a brief explanation for the parameter they wish to view/edit. This is usually used as a reminder of what the parameter does without having to refer to this user manual.

This user manual must be read first before operating the machine as the Help Screens serve to only supplement the manual.



*Note: Most parameters names (in white text) will link to a Help File*

# Main Screen

The Main Startup screen is the primary screen and is shown when the machine powered up.

operator is first



Item	Function
UNIFILLER LOGO	The Unifiller Systems banner on all screens accesses the Unifiller Systems screen which shows Unifiller Systems contact information as well as the software revision.
CURRENT ACCESS LEVEL	Displays the security access level which is currently logged in.
RECIPE	Displays the recipe number and recipe name that is currently loaded.
SHIFT CYCLES	Displays the current count of cycles that have been done since the last reset. This count can be reset using the Reset Shift Cycles button on the Statistics screen.
CURRENT ALARM	Displays the current alarm found anywhere along the line.
ACTUAL PRODUCTION RATE	Displays how many cycles the machine is doing per minute at the current rate. This may be different than the set production rate because the line may have to wait for the depositor feedback to be done, etc.
RECIPE Button	Accesses the Load Recipe screen which allows the operator to load a recipe when the machine is not running. It also gives access to the Save Recipe screen. This screen is described further on in this document.

Continued on the next page...

## Main Screen Continued...

The Main Startup screen is the primary screen and is shown when the machine powered up.

These are more features of the Main screen which were not covered on the page.

The main screen contains the following and displays:



Item	Function
ALARM HISTORY Button	Accesses the Alarm History screen which displays the most recent alarms that have occurred with details of when they occurred.
SYSTEM Button	Accesses the System screen which allows the operator to: change parameters that affect how the machine runs, and access to the technical screen. This screen is described further on in this document.
MODE Button	Accesses the Mode screen which allows the operator to turn on/off Test Mode for machine endurance testing.
STATISTICS Button	The Statistics button accesses the Statistics screen, which allows the operator to view, the Actual Production Rate, Actual Cycle Time, Runtime hours, Total Cycles, Shift Cycles and Main Air Status. The Statistics screen also allows the operator to reset the Shift Cycles counter.
CLEAN SCREEN Button	Accesses the Clean screen which is empty and allows the operator to wipe the screen without accidentally changing machine settings. This screen is described further on in this document.
LOGIN / LOGOUT Button	Accesses the Login screen allows the operator to enter a password for a higher security level. These levels include: Operator, Supervisor, Technical, and Factory. A higher security level has access to more features as well as all of the features lower levels have access to. These security levels are mentioned if they are required for certain screens. This screen is described further on in this document. If a user is currently logged in, the button will show LOGOUT and can be pressed to logout any higher security level back to the Operator level.

## Station #1 Depositor

The Station #1 Depositor screen is accessed from the Main screen by pressing the station image. This screen allows the operator to adjust parameters for the deposit.

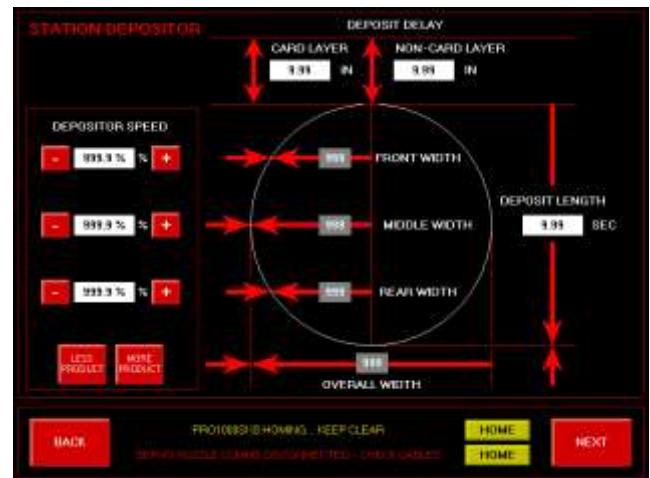

Item	Function
DEPOSIT DELAY	Deposit Delay sets the distance, in inches, that the conveyor will travel before the nozzle opens, after a cake is detected by the photo sensor.
DEPOSITOR SPEED	The plus and minus buttons as well as the more product and less product impact the amount of product being dispensed in each on the zones (front, middle and back). The buttons increment and decrement in values of 1%.
MORE PRODUCT button	The more product button when pressed increases the depositor speed in all three zones by 1%.
LESS PRODUCT button	The less product button when pressed increases the depositor speed in all three zones by 1%.
FRONT WIDTH	The arrows adjust the width of the front third of the icing layer.
MIDDLE WIDTH	The arrows adjust the width of the middle third of the icing layer.
REAR WIDTH	The arrows adjust the width of the rear third of the icing layer.
OVERALL WIDTH	The arrows adjust the overall width of the icing (Increases/decreases all values). The overall width will set the maximum the nozzle will open.
DEPOSIT LENGTH	Deposit length is the length of time, in seconds that the nozzle will take to open and close. A longer time will result in a longer deposit. The arrows adjust the overall length of the icing.

## Station #1 Pro1000SI

The Station #1 Pro1000SI Screen is accessed by pressing the next button on the Station #1 Depositor screen. This screen will only appear when the Pro1000si is connected to the main control box.

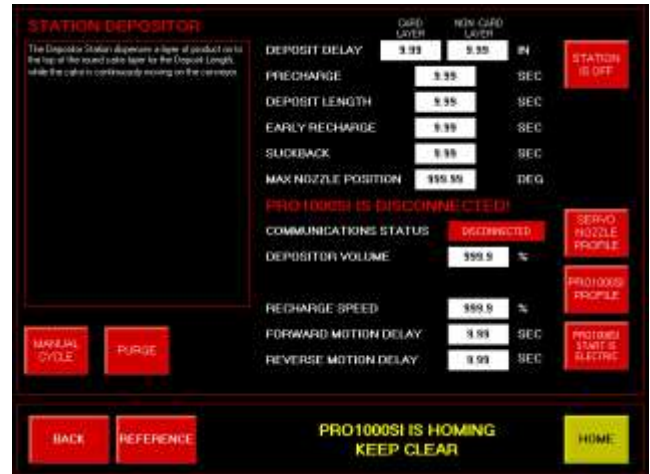

Item	Function
DEPOSIT DELAY	Deposit Delay sets the distance the station will wait for the conveyor to move before opening nozzles. The Card Layer delay will be used for the first layer of the cake which is placed on a cardboard. The Non-Card Layer will be used for all other layers of the cake, which are placed directly onto the conveyor belt.
PRECHARGE	Precharge sets the time the product will be pressurized at the nozzles before being deposited. This ensures a consistent deposit from beginning to end. If too little product comes out at the beginning, increase the precharge.
STICK TIME	Stick Time sets the amount of time the product will dispense while the cake is stopped before the conveyor starts to move. This is used to make sure the dispensed product touches the cake before moving.
DEPOSIT LENGTH	Deposit Length sets the time the servo nozzle will take to complete one deposit cycle. This time should be set long enough to allow the desired length of product to be dispensed, increasing the time will produce a longer deposit, and decreasing it will produce a shorter product.
EARLY RECHARGE	Early Recharge sets the amount of time before the nozzle closes, that the depositor will be forced to recharge. If its value is set to zero, the depositor will recharge when the nozzle closes. If it is set to a non-zero value, the depositor recharge signal will be triggered that much time before the nozzle closes.
SUCKBACK	Suck back sets the length of time after the deposit has occurred that the nozzle(s) will stay open to allow the product to be sucked back in to prevent drips and create good cutoff. This helps prevent a mess and produces better decoration.

MAX NOZZLE POSITION	Max Nozzle Position sets the fully open position, in degrees, of the servo nozzle, and it needs to be adjusted based on what size nozzle insert is currently being used. This parameter should match the degrees marked on the specific nozzle insert currently installed.
COMMUNICATIONS STATUS	Communication Status indicates if the Stand Alone communications are working.
DEPOSITOR VOLUME	Depositor Volume sets the largest possible volume of product that can be deposited during a cycle. Typically, the depositor will not complete a full stroke as the line will force the Pro1000SI to recharge. This parameter should only be adjusted if the depositor is short stroking. Use the ProSI speed profile to adjust deposit weights.
RECHARGE SPEED	Recharge Speed sets how fast the Pro1000si will draw product from the hopper to fill the product cylinder. This should be set fast enough so that the depositor is ready for the next cycle, but not so fast that the product becomes damaged or is not drawn in correctly.
FORWARD MOTION DELAY	Forward Motion Delay sets the amount of time between when the Pro1000SI product valve opens and when the piston starts to move forward. This is used to allow the Pro1000SI product valve to fully open before pumping product.
REVERSE MOTION DELAY	Reverse Motion Delay sets the amount of time between when the Pro1000SI product valve closes and when the piston starts to recharge. This is used to allow the Pro1000SI product valve to fully close before pulling product form the hopper.
STATION IS ON/OFF button	This button enables or disables the station from cycling when a product triggers the photo sensor. The stat of this button is saved when the recipe is saved.
SERVO NOZZLE PROFILE	Accesses the Servo Nozzle Profile screen where the operator can adjust the motion of the servo nozzle
PRO1000SI PROFILE	Accesses the Pro1000si profile screen where the operator can adjust the motion of the Pro1000si.
PRO1000SI START IS ELECTRIC/COMMS	Sets the method of sending the deposit start signal to the Pro1000si. If electric is selected a discrete output is used, if Comms is selected, the start signal is sent over communications. Electric is the preferred mode.
REFERENCE button	Navigates the user to the references screen.
MANUAL CYCLE button	Allows the operator to start a manual cycle where the machine will complete one full cycle using the entered parameters.
PURGE button	This button allows the operator to purge product from the depositor.

## Station #1 Servo Profile

The Station #1 Servo Profile screen can be accessed from the Station #1 Pro1000SI screen by pressing the Servo Profile button. On this screen the operator can change in more depth the profile of how the deposit will look.

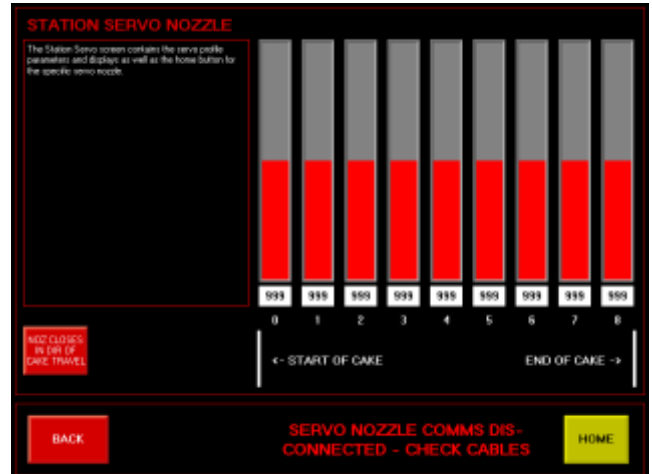

Item	Function
Profile at zone 0	Sets size of the servo nozzle profile at zone 0. The percentage determines what portion of the maximum width the nozzle will open while depositing. The sections are split into 9 equal sections.
Profile at zone 1	Sets size of the servo nozzle profile at zone 1.
Profile at zone 2	Sets size of the servo nozzle profile at zone 2.
Profile at zone 3	Sets size of the servo nozzle profile at zone 3.
Profile at zone 4	Sets size of the servo nozzle profile at zone 4.
Profile at zone 5	Sets size of the servo nozzle profile at zone 5.
Profile at zone 6	Sets size of the servo nozzle profile at zone 6.
Profile at zone 7	Sets size of the servo nozzle profile at zone 7.
Profile at zone 8	Sets size of the servo nozzle profile at zone 8.
NOZ CLOSES/OPENS IN DIR OF CAKE TRAVEL	Sets the direction of rotation based on how the nozzle was inserted into the body.

## Station #1 PRO1000SI PROFILE

The Station #1 Pro1000SI Profile screen allows the operator to vary the speed of the PRO1000SI depositor during the dispensing cycle. This allows the machine to change the speed at which the product is dispensed to compensate for changes in the nozzle opening (size). If Speed Profiling is turned off, the speed will remain constant through dispensing cycle and is set on the depositor screen.

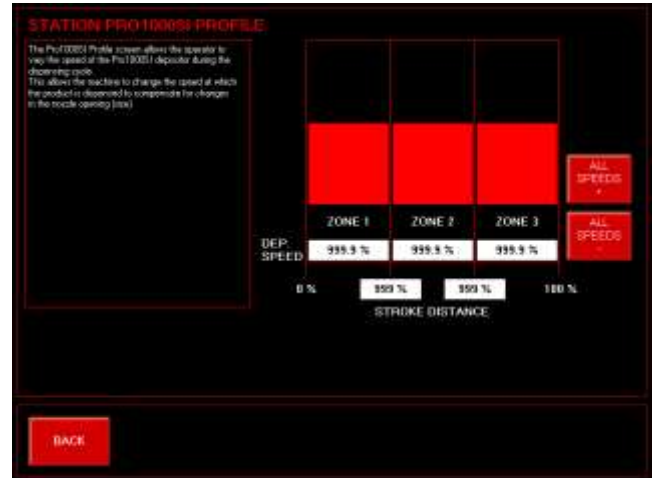

Item	Function
ZONE 1 SPEED	Sets desired speed of zone 1 cycle. This will determine the speed for the time of the stroke in zone 1.
ZONE 2 SPEED	Sets desired speed of zone 2 cycle.
ZONE 3 SPEED	Sets desired speed of zone 3 cycle.
STROKE DISTANCE	Stroke Distance sets how much of the cycle that the piston will move at the corresponding Zone Speed. Stroke Distance is referenced as a percentage of the current Depositor Volume setting.
ALL SPEEDS +	Increase all speed profiles by 1 of the PRO-1000SI.
ALL SPEEDS -	Decrease all speed profiles by 1 of the PRO-1000SI.

## Station #1 References Screen

The Station #1 Servo Profile screen can be accessed from the Station #1 Pro1000si by pressing the Reference button. On the Station #1 reference screen the operator can record manual settings that are associated with the station which may need to be adjusted on a per recipe basis.



Item	Function
BRIDGE HEIGHT	Bridge Height refers to the height of the nozzles located on the bridge. The height should be adjusted for the cake height and desired look of the product being dispensed. The measurement can be found on the bridge and is adjusted using the hard crank.
PRODUCT CYLINDER SIZE	Product Cylinder Size refers to the diameter of the product cylinder currently being used. Larger cylinders allow for more product to be able to be dispensed.
NOZZLE TYPE	Nozzle Type allows the operator to record the type of nozzle currently being used as well as any fitting or accessories associate with the nozzle. This is a text based reference and a short description can be entered by the operator.
NOZZLE INSERTION	Nozzle Insertion refers to the distance that the Pro1000si outlet is inserted into the servo nozzle. Changing this distance will affect product flow inside the nozzle.

## Statistics Screen

The Statistics screen can be accessed from the Main screen by pressing the STATISTICS button. This screen allows the operator to view statistical information. This screen allows the operator to access the Statistics screen.



Item	Function
ACTUAL CYCLE TIME	Displays how long the depositor takes for one full cycle.
ACTUAL PRODUCTION RATE	Displays how many cycles the depositor is doing per minute at the current rate.
TOTAL CYCLES	Total Cycles indicates how many shells the machine has done in its life time. Note: This count cannot be reset
TOTAL HOURS	Runtime Hours indicates how many hours the machine has ran in production in its lifetime. Note: This time cannot be reset.
PRODUCT Counter	This shows the counts for the current product run (in green) as well as historical product runs (1-5 in yellow). The graphs are all shown compared to the greatest run in the set of 6.
NEW PRODUCT Button	This button moves all product runs over 1 historical position. The last product run (5) is lost and the current product run is reset for a new count. This is usually used when a new product run is started.
RESET CURRENT PRODUCT Button	This button is used to zero the current product run count. This is usually used if the current count is not needed and needs to be started again.
SHIFT CYCLES	This shows the counts for the current shift (in green) as well as historical shifts (1-5 in yellow). The graphs are all shown compared to the greatest shift cycle count in the set of 6.
NEW SHIFT Button	This button moves all shifts over 1 historical position. The last shift (5) is lost and the current shift is reset for a new count. This is usually used when a new shift (day) is started.
RESET CURRENT SHIFT Button	This button is used to zero the current shift count. This is usually used if the current count is not needed and needs to be started again.

## Recipe Screen

The Recipe screen is accessed from the Main screen by pressing the RECIPE button. This screen allows the operator to load recipes while the machine is not running.



Item	Function
+ Button	This button allows the operator to scroll through the recipes by increasing the recipe number. The name of the recipe will appear in the Recipe Name To Load dialog box below the number.
- Button	This button allows the operator to scroll through the recipes by decreasing the recipe number. The name of the recipe will appear in the Recipe Name To Load dialog box below the number.
CURRENT RECIPE	The recipe name and number indicates the current recipe selected. Each Recipe holds parameter values to make a specific product.
NEW RECIPE	The recipe name and number indicate the desired recipe to save or load. Each Recipe holds parameter values to make a specific product.
LOAD RECIPE Button	Allows the operator to load the recipe that is currently selected in the Select Recipe parameter field.
SAVE RECIPE	Allows the operator to save the currently loaded recipe.

## Mode Screen

The Mode screen is accessed from the Main screen by pressing the MODE button. On the mode screen the different modes can be toggled on and off.



Item	Function
WASHDOWN MODE	In Washdown Mode the conveyors will run continuously for cleaning until the stop button is pressed or the mode is turned off. Washdown Mode uses the Washdown Speed to control the speed of the conveyor.
TEST MODE	In test mode the machine will cycle continuously for testing and troubleshooting until the stop button is pressed or the mode is turned off. This can be used to set up the machine. Note: The green run light will flash.
WASH IS ON/OFF Button	This button turns on and off the Washdown Mode.
TEST IS ON/OFF Button	This button turns on and off the test mode.

## System Screen

The System screen can be accessed from the Main screen by pressing the SYSTEM button. The System screen contains parameters related to the overall system, such as the production rates (as opposed to parameters for individual stations).



Item	Function
SYSTEM TIME	System Time displays the current date and time set in the PLC and allows the user to change the current date and time. This is mainly used in the Alarm History Screen.
CONVEYOR SPEED	Conveyor Speed sets the speed at which the conveyor will move, during normal operation.
LAYERS PER CAKE	Layers per Cake should be set to the number of layers used per cake produced. This is used by the stations in order to determine which layer is the top layer, which will not be deposited on. This parameter is also used to determine the rate at which to flash the pace lights.
CURRENT LAYER COUNTS	Current Layer Counts displays the current cake layer number being counted by either the pace lights or the depositor.
PACE LED	Pace LED shows the current cake layer counted by the Pace lights. If a false photo eye has caused an error in the count, press and hold the Reset Layer Counts button, or stop the line and press and hold the stop button for five seconds.
DEPOSITOR	Depositor shows the current cake layer counted by the station Depositor. If a false photo eye has caused an error in the count, press and hold the Reset Layer Counts button, or stop the line and press and hold the stop button for five seconds.

# Alarm History Screen

The Alarm History screen is accessed from the Main screen by pressing the ALARM HISTORY button. It displays the alarm type, and date and time the alarm was triggered.



## Technical Screen

The Technical screen is accessed from the System Screen by pressing the TECHNICAL button. This screen allows the Technician to change technical parameters and functions that affect the entire system and are changes seldom. Technicians can use this screen to disable some sensors and troubleshoot problems. These parameters do not need to be changed often and affect how the machine runs.

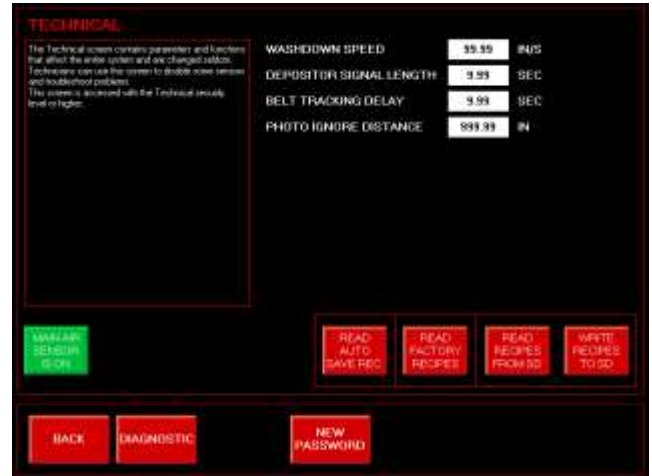

Item	Function
MAIN AIR SENSOR IS ON/OFF Button	Enables or disables the main air sensor. It allows the operator to run the line in the event of failure by disabling the air sensor.
READ AUTO SAVE REC. Button	This button appears when a SD card is inserted into the back of the HMI screen. It allows the Technician to restore auto save recipes from the SD card. <b>Important: This will replace all current recipes on the PLC.</b>
READ FACTORY RECIPES Button	This button appears when an SD card is inserted into the back of the HMI screen. It allows the Technician to restore all of the factory default recipes from the SD card. <b>Important: This will replace all current recipes on the PLC.</b>
READ RECIPES FROM SD Button	This button appears when a SD card is inserted into the back of the HMI screen. It allows the Technician to restore previously saved recipes from an SD card. <b>Important: This will replace all current recipes on the PLC.</b>
WRITE RECIPES TO SD Button	This button appears when a SD card is inserted into the back of the HMI screen. It allows the Technician to backup all of the recipes onto an SD card. This button will be disabled if the SD card is locked.
DIAGNOSTIC button	Accesses the Diagnostic screen which allows the operator to view the diagnostics screens.
NEW PASSWORD	Accesses the New Password screen which lets the operator enter a new numerical password for a selected security level.
WASHDOWN SPEED	Sets the speed of the conveyor when the machine is in Washdown Mode. This is usually set to the lowest possible speed.

DEPOSITOR SIGNAL LENGTH	Sets the length of time the signal will stay on to trigger the depositor. This is usually set to 0.25 seconds.
BELT TRACKING DELAY	Belt Tracking Delay sets the time from when the belt photoeye senses a steady change in belt position until the belt tracking cylinder is activated. This is used to prevent the cylinder from constantly cycling.
PHOTO IGNORE DISTANCE	Photo Ignore Distance sets the distance in inches that the conveyor will move, that the system will ignore the photo eye, after the cake layer count has been reset.

## New Password Screen

The New Password screen is accessed from the Technical screen by pressing the NEW PASSWORD button. This screen allows the Technician to change the Supervisor and Technician access level passwords.

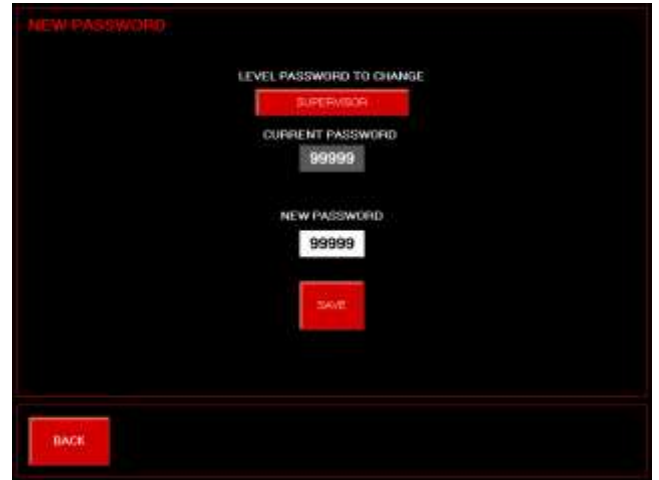

Item	Function
LEVEL PASSWORD TO CHANGE button	Allows the operator to select which security level password (Supervisor or Technician) is being changed.
CURRENT PASSWORD	Displays the numerical password that currently exists for the selected security level.
NEW PASSWORD	Displays the new numerical password for the selected security level.
SAVE Button	Allows the operator to save the new password.

# Clean Screen

The Clean screen is accessed from the Main Startup screen by pressing the CLEAN SCREEN button. This screen allows the operator to wipe the screen without accidentally changing parameters or pressing buttons.

The Back button returns to the Main Startup screen when pressed after the duration of the 10 second clean screen countdown.

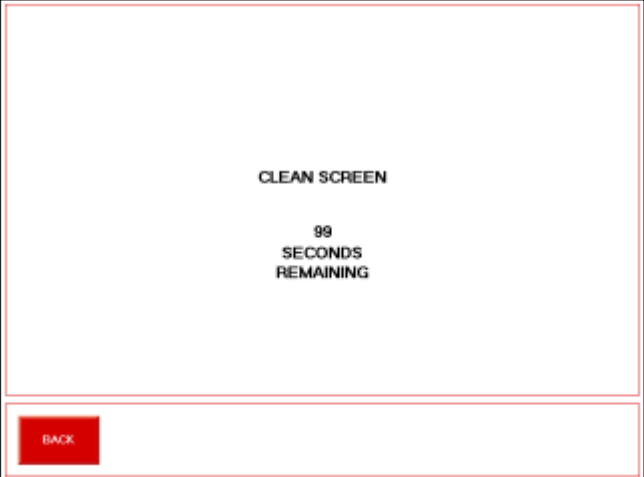

## Login Screen

The Login Screen is accessed by pressing LOGIN button on the Main Screen or when a higher security level is required to enter a specific screen.



Item	Function
CURRENT ACCESS LEVEL	This dialog box shows the current logged in access level. These levels include Operator, Supervisor and Technician. A higher security level has access to more features as well as all of the lower access level features.
ENTER PASSWORD	This field allows the operator to type in the password from the numeric touchpad. The logged in security level will change if the password is correct.

## Diagnostics Screen

The Diagnostics screen is accessed from the Technical screen by pressing the DIAGNOSTICS button. This screen allows the Technician to navigate to the Inputs, Outputs and Ethernet Communications screens.



### WARNING:

The machine must be stopped before entering the diagnostics screens. Damage may occur when forcing outputs. Make sure people and objects are clear of moving parts before activating outputs.

Item	Function
FORCING IS ENABLED/DISABLED Button	Allows the Technician to enable or disable forcing of outputs.
INPUTS Button	Accesses the Diagnostics - Inputs screens which the Technician can use to test and monitor inputs.
OUTPUTS Button	Accesses the Diagnostics - Outputs screens which also gives access to the Analog Outputs screen.
UNICAN COMMS	This button access the Diagnostics UniCAN Communications screen. This screen is used to monitor the status and connectivity of the UniCAN communications system which talks to the PRO1000SI depositors when they are connected.
CANOPEN COMMS	Accesses the Diagnostics – CanOpen Communications screen where information on the status of the CanOpen network can be viewed. This screen is used to monitor the status and connectivity of the CANOpen communications system which talks to the servo nozzles.
ETHERNET COMMS	Accesses the Diagnostics – Ethernet Communications screen where information on the status and settings of the Ethernet card can be viewed.

## Diagnostics – Inputs Screens

The Diagnostics – Inputs screens are accessed from the Diagnostics screen by pressing the INPUTS button. This screen allows the Technician to read inputs that are connected to the PLC.

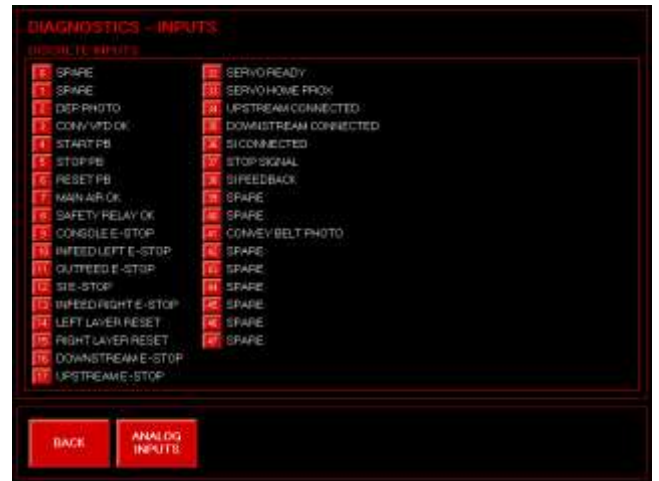

Item	Function
DISCRETE INPUTS	Inputs are shown as red indicators. The red indicator will turn green when the input is ON. The name of the device is shown beside each indicator.
ANALOG INPUTS Button	Allows access to the Analog Inputs screens.
ANALOG INPUTS	Displays the analog input parameters.

## Diagnostics – Outputs Screens

The Diagnostics Outputs screens are accessed from the Diagnostics Menu screen by pressing the OUTPUTS button. The Discrete Outputs screen allows the Technician to force discrete outputs that are connected to the PLC on. The Analog Outputs screen allows the Technician to change the analog output values that are connected to the PLC.



### WARNING:

Ensure people and loose parts are clear of moving parts before forcing outputs, otherwise severe injury or machine damage may result.

Item	Function
DISCRETE OUTPUTS	Outputs are shown as red buttons. These buttons can be pressed to force each output ON. The red button will turn green when the output is forced ON.
ANALOG OUTPUTS Button	Allows access to the Analog Outputs screen.
- Button	Decreases the value of the analog output by 1 percent (0-100% range). This button can be pressed for a single digit change or held to change digits rapidly.
+ Button	Increases the value of the analog output by 1 percent (0-100% range). This button can be pressed for a single digit change or held to change digits rapidly.

## Diagnostics - UNICAN Communications Screen

The Diagnostics Unican Communications screen is accessed from the Diagnostics screen by pressing the UNICAN COMMS button. This screen provides the option to modify connection settings. The UNICAN Network is used to send parameters to the PRO1000SI depositors.



The Diagnostics UNICAN Communications screen contains the following functions and displays:

Item	Function
PRO1000SI	The name stand alone is to indicate that there is a machine connected to the line.
BUFFER STATUS	Displays if the Buffer is ok or not
COMMS STATUS	Displays the status of Comms and if it is ok or not.
COMMS ERROR MESSAGE	Displays if any errors occur with the Canopen Comm system.
MESSAGE TO SEND	Displays the number of messages currently on the send buffer.
RECEIVED WAITING	Displays the number of messages currently on the receive buffer.
MESSAGES SENT	Displays the total number of messages sent.
MESSAGES REVEIVED	Displays the total number of messages received.
UNIT ERROR BITMAP	Displays the value of the Unitronics communication unit error bitmap , which indicates which unit has faulted.
COMM ERROR VALUE	Displays the communications error value. The corresponding message is displayed in the Comms Error Message window.

## Diagnostics - CANOPEN Communications Screen

The Diagnostics CANOPEN Communications screen is accessed from the Diagnostics screen by pressing the CANOPEN COMMS button. This screen provides the option to modify connection settings. The CanOpen Network is used to send parameters to the servo nozzles.

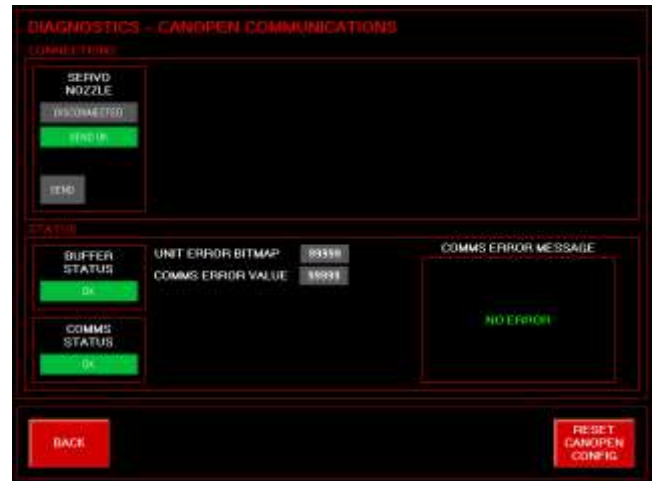

The Diagnostics Canopen Communications screen contains the following functions and displays:

Item	Function
SERVO NOZZLE STATUS	Displays if the servo nozzle is connected or disconnected.
BUFFER STATUS	Displays if the Buffer is ok or not
COMMS STATUS	Displays the status of Comms and if it is ok or not.
COMMS ERROR MESSAGE	Displays if any errors occur with the Canopen Comm system.
UNIT ERROR BITMAP	Displays the value of the Unitronics communication unit error bitmap , which indicates which unit has faulted.
COMM ERROR VALUE	Displays the communications error value. The corresponding message is displayed in the Comms Error Message window.
RESET CANOPEN CONFIG Button	Refreshes/Initializes the settings of the Canopen configurations.

## Diagnostics - ETHERNET Communications Screen

The Ethernet Communications screen is accessed from the Diagnostics screen by pressing the ETHERNET COMMS button. This screen provides the option to modify Ethernet settings. An Ethernet connection allows the PLC to be connected to a central control room or to be accessed remotely.

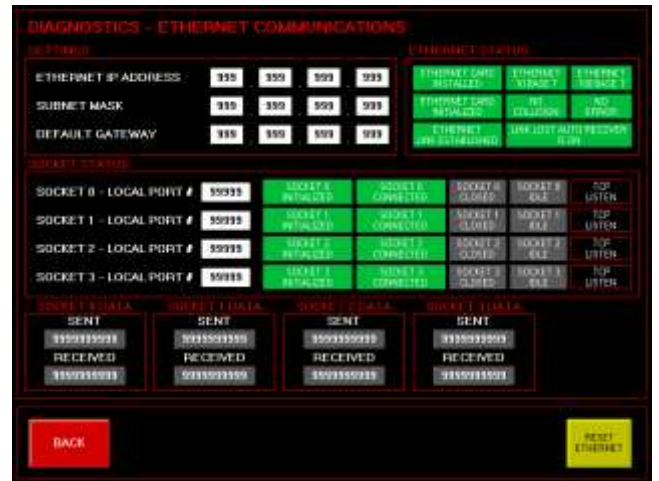

The Diagnostics Ethernet Communications screen contains the following functions and displays:

Item	Function
SETTINGS	Displays the Ethernet IP Address, Subnet Mask and Default Gateway.
ETHERNET STATUS	Displays Ethernet information and hardware status.
SOCKET STATUS	Displays the status of Socket 0 to 3 and their respective port numbers, as well as if the sockets are initialized/not initialized, connected/not connected, open/closed status and idle/sending.
SOCKET DATA	Displays the amount of data sent and received for Socket 0 to 3.
RESET ETHERNET	Refreshes/Initializes the settings of the Ethernet card in the PLC.

# Troubleshooting

## No Air Pressure

- Check that the air supply is connected and the red switch by the air supply is turned on.
- Check that the pressure is at 80 PSI.
- Make sure the E-Stop dump valve is turned on by the regulator.
- If the above steps have been taken, then the main air sensor may need to be adjusted or replaced.



## Console/Rope/Pro1000si E-Stop Condition

- Check that all E-Stop buttons are pulled out. The screen will usually indicate which E-Stop is activated.
- Wait for all drives to shut down before resetting the E-Stop condition.
- Press the Reset button on the front panel to reset the E-Stop condition.



### Safety System Did Not Reset

- Inspect all E-stop button and guards to ensure that they are fully reset.
- Inspect all E-stop connections.



### Downstream/Upstream E-Stop Condition

- Check that all E-Stop buttons on downstream and/or upstream modules are pulled out. The screen on the E-Stopped module will usually indicate which E-Stop is activated.
- Wait for all drives to shut down before resetting the E-Stop condition.
- Press the Reset button on the front panel to reset the E-Stop condition.



### Downstream/Upstream Not Connected

- Connect either the downstream or upstream module, or the safety cover.





### Conveyor Drive Fault

- Check the error message on the drive and refer to the drive's User Manual.
- Try resetting the drive by cycling the power. If the problem persists, the drive may need to be replaced.
- Check all connections between the conveyor and panel.



### Pro1000SI Low Air Pressure

- Check that the air supply is connected and the red switch by the air supply is turned on.
- Check that the pressure is at 80 PSI.
- Make sure the E-Stop dump valve is turned on by the regulator.
- If the above steps have been taken, then the air sensor may need to be adjusted or replaced.



### Pro1000SI Feedback Problem

- Check that the feedback connection is secure between the depositor and the control box.



### PRO1000SI Servo Actuator Fault

- Check to see why the actuator may have faulted (physical jam or electrical issue).
- Ensure that the actuator's movement is not obstructed in any way.
- Turn off the machine and wait 10 seconds and then turn on and re-home the machine.



### PRO1000SI Not Connected

- Ensure both yellow and grey integration cables are connected to the Pro1000SI.



### PRO1000SI Safety System Did Not Reset

- Inspect the E-stop button to ensure it is fully reset.
- Inspect all E-stop connections on the Pro1000SI.



### PRO1000SI Homing Timed Out

- Ensure there are no faults on the Pro1000SI.
- Ensure that the actuator's movement is not obstructed in any way.
- Turn off the machine and wait 10 seconds and then turn on and re-home the machine.



### Servo Nozzle COMM Disconnected

- Check all connections to the servo motor.
- Check connections to control panel.
- Reset Canopen Configuration

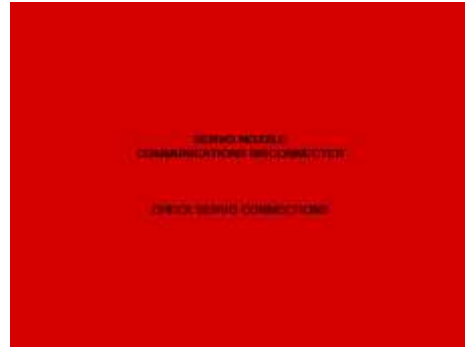

### Servo Nozzle COMM in stop mode

- Check all connections to the servo motor.
- Check connections to control panel.
- Reset Canopen Configuration



### Servo Nozzle Servo Did Not Finish

- Check all connections to the servo motor.
- Check connections to control panel.
- Check motor for faults.
- Press stop to clear.
- Check for obstructions in the way of the servo rotation.



### Servo Nozzle Homing Timed Out

- Check all connections to the servo motor.
- Check connections to control panel.
- Check motor for faults.
- Press stop to clear.
- Check for obstructions in the way of the servo rotation.



### PRO1000SI Home Needed

- **Make sure the machine is clear of parts and people before homing!**
- Home the depositor by pressing the Home button on the Depositor Station Screen or on the Pro1000SI screen.



### PRO1000SI Is Homing

- **Make sure the machine is clear of parts and people before homing!**
- The PRO1000SI is currently homing the depositor to its set home position.

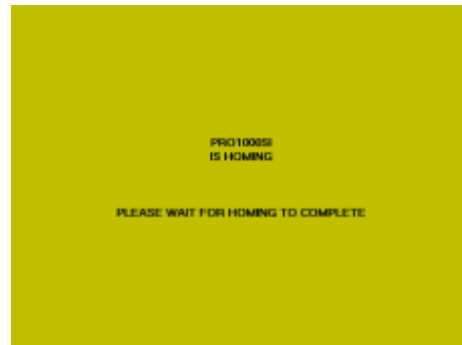

### Servo Nozzle COMM in PRE-OP Mode

- Parameter transfer not affected.
- Reset CANOPEN Network.



### Servo Nozzle Home Needed

- **Make sure the machine is clear of parts and people before homing!**
- Home the servo nozzle by pressing the Home button on the servo nozzle Station Screen.



## Disassembly, Cleaning and Sanitizing



This machine is designed for Rapid sanitation, but not full wash down.

Failure to adhere to the cleaning and maintenance instructions detailed in this manual could affect the warranty of this machine.

- Do not steam clean or use a pressure washer
- All outer surfaces of the machine enclosure should be wiped down daily dry or with warm soapy water.
- All food contact parts (hopper, blocks, pistons and nozzles) can be removed from the machine for thorough cleaning. These parts are full wash down when removed from the machine.



- Abrasive materials may damage finish of this equipment.

Use of the following types of cleaning agents is not acceptable and may cause damage to the Machinery that the manufacturer cannot be held responsible for.

Check specifications and warnings on labels of all cleaning products prior to use.

- Cleaning agents containing chlorine or chlorides may cause spotting
- Acidic or alkaline solutions can cause corrosive reactions between dissimilar metals as are found in this machine such as bearing housings and electrical conduit.
- Solvent, Aromatic or chemically reacting solutions may cause damage to synthetic materials such as rubber contained in the electrical seals or seals of mechanical drive components.

**DO NOT UNDER ANY CIRCUMSTANCES USE A WATER HOSE OR PRESSURE WASHER TO CLEAN THE ENCLOSURE OF THESE MACHINES.**

## General Instructions

Sanitizing requires that the machine must be disassembled.

- Turn air off (1) by sliding red valve downwards and remove supply line from machine.
- Scrape down the inside of the hopper.
- Reconnect supply line and turn Air on. by sliding red valve upwards
- Disassemble all parts shown in the 'Cleaning and Sanitizing' section (Follow the procedure described in 'Disassembling section')
- Wash them thoroughly, ensure the plastic parts are not placed on sharp Surfaces in the dishwasher.
- Connect the red and black quick connects together. This will stop water from entering the air cylinders during cleaning.



**DO NOT SUBMERGE THE AIR CYLINDERS IN WATER**



## Disassembling

### PRO1000si – STEP 1

- Unclamp the hose (1), pressure relief valve (2) from the servo nozzle and the depositor

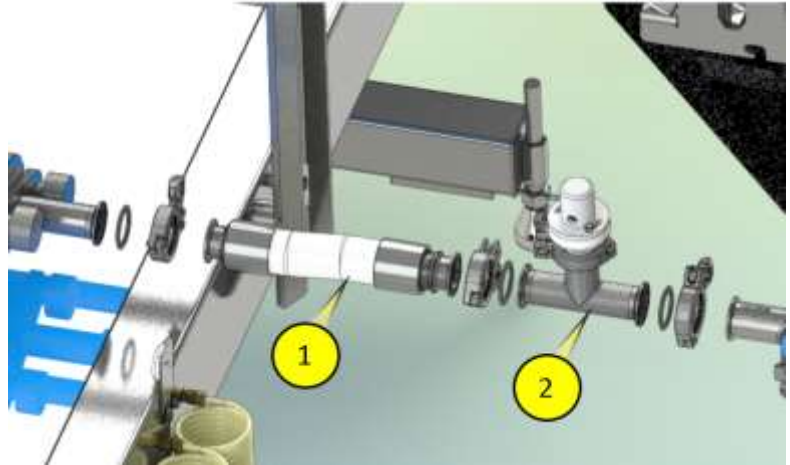

### PRO1000si – STEP 2

- Disconnect the airline and remove the stirrer box (2) and disassemble the paddle by rotating it counter-clockwise (1).

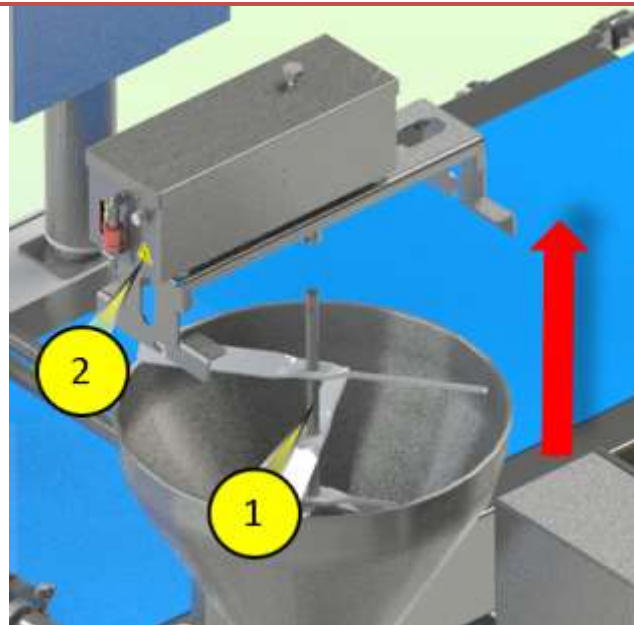

### PRO1000si & Mid-Fill – STEP 3

- Untighten hopper nut and remove hopper (3) from valve body (2)
- Place gasket in safe location (1)
- Remove Hopper and place top downwards on a sanitary surface

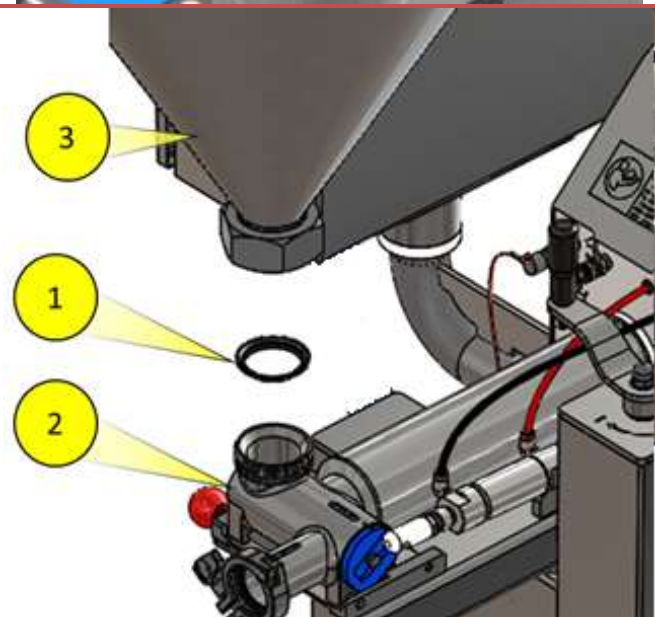

PRO1000si – STEP 4

- Remove red safety pin (1) from valve body

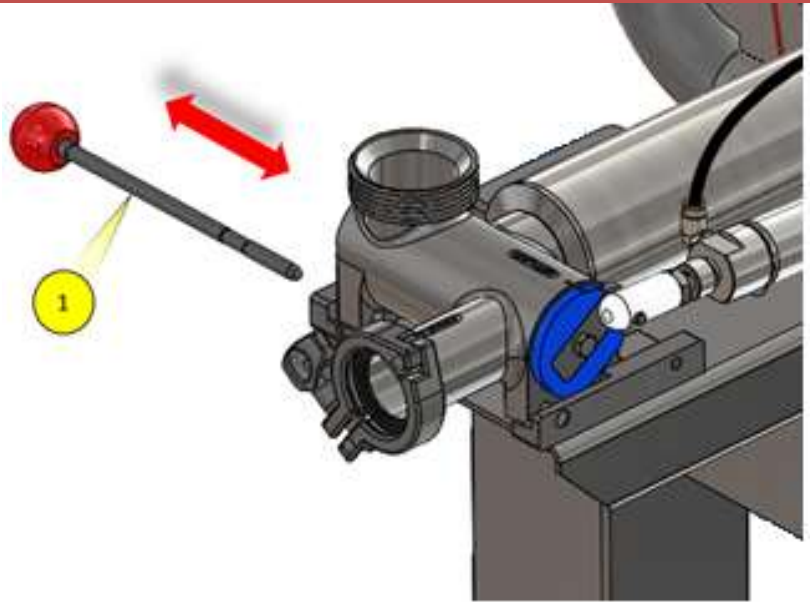

PRO1000si – STEP 5

- Remove red safety pin (1) from valve body

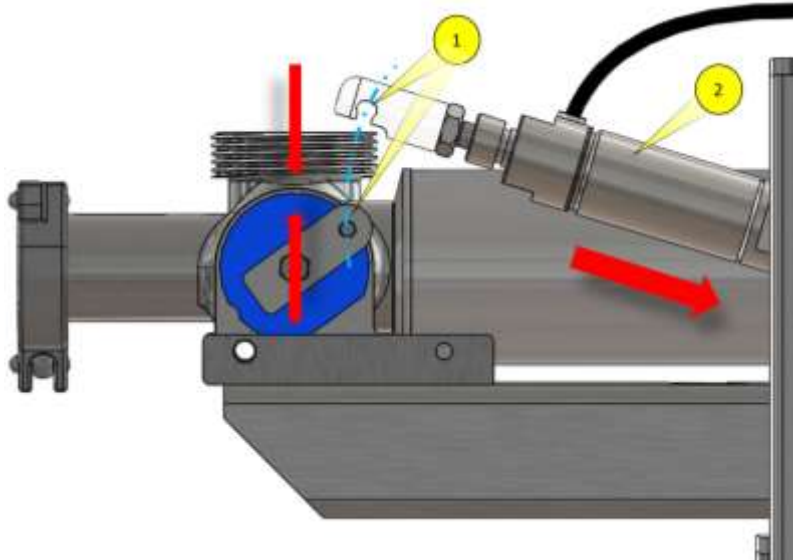

PRO1000si – STEP 6

- Remove red safety pin (1) from valve body

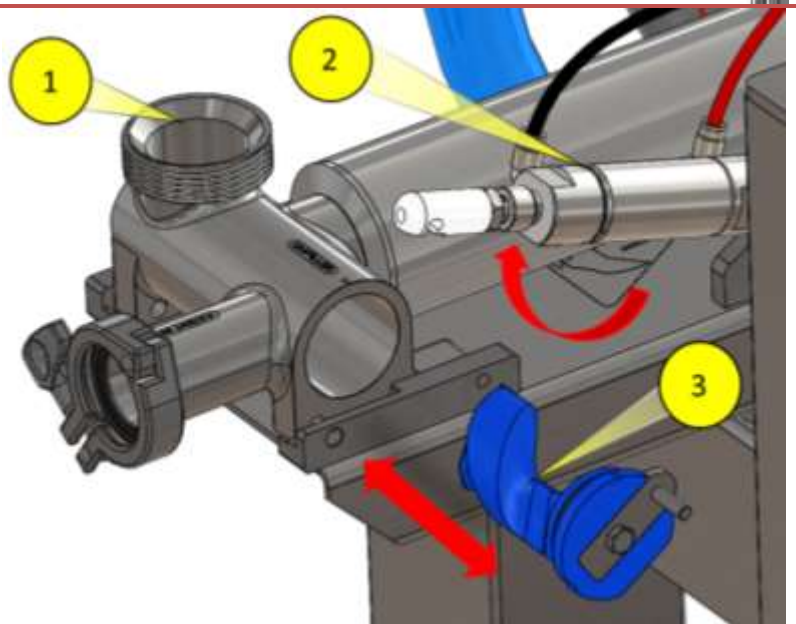

PRO1000si – STEP 7

- Remove red safety pin (1) from valve body

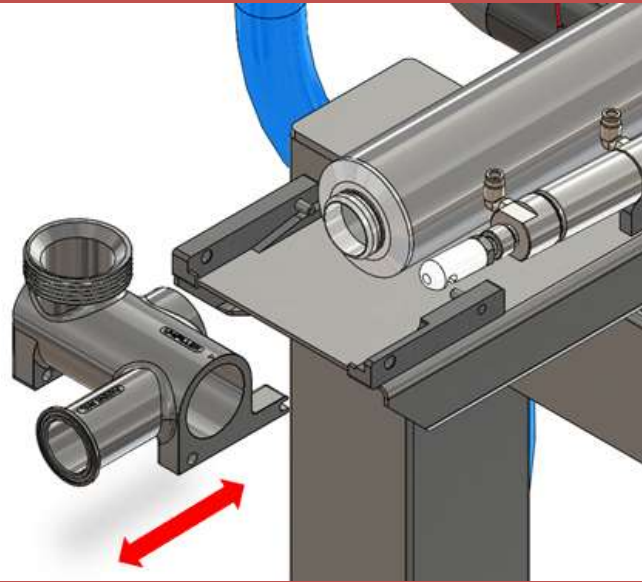

PRO1000si – STEP 8

- Remove the product cylinder (1) outward direction.

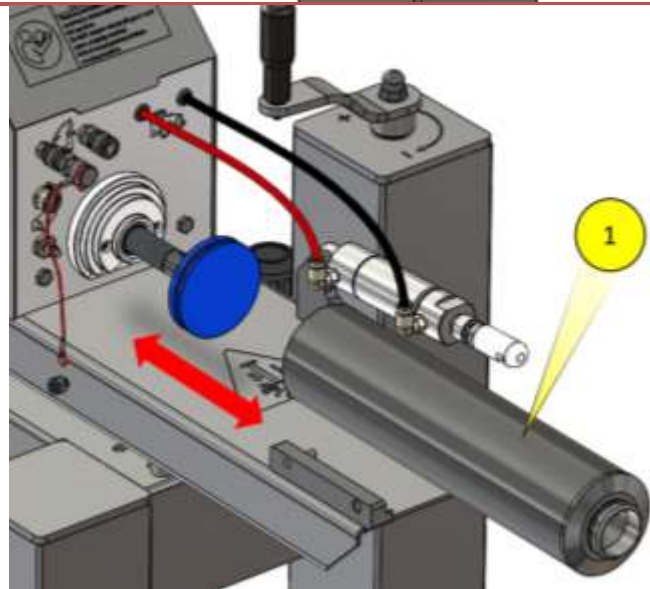

PRO1000si – STEP 9

- Remove the product piston (1)

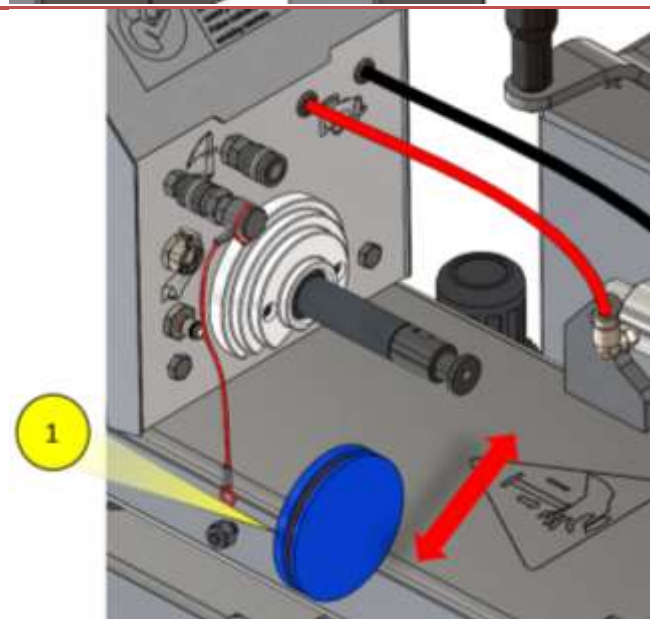

Servo Mid-Fill– STEP 10

- Loosen up the knobs (1) and remove the tube (2) and end cap (3)

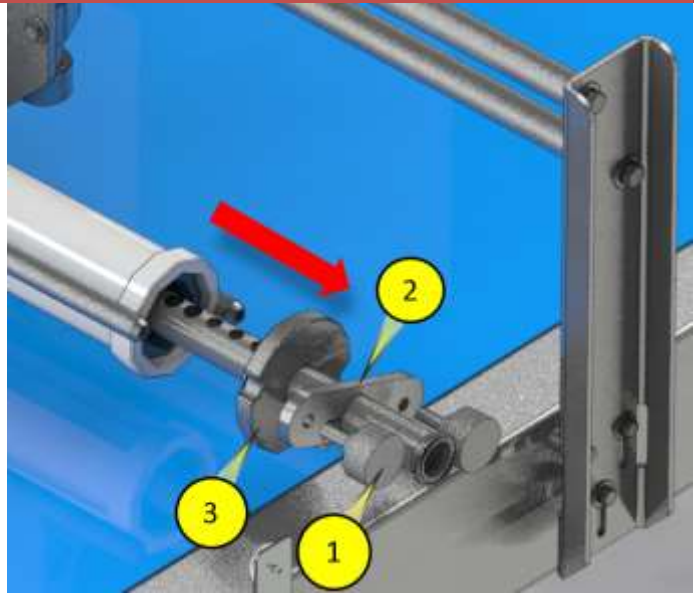

Servo Mid-Fill– STEP 11

- Slide the nozzle body (1) and the end plate (2) off the rods

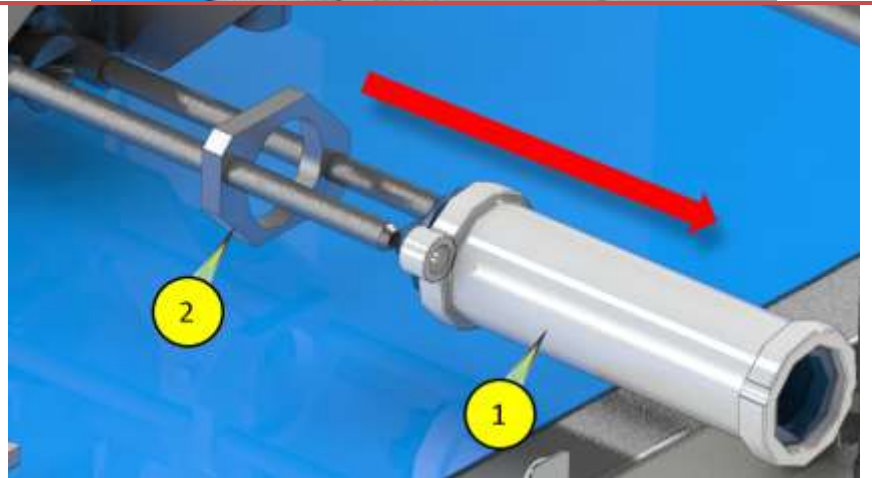

Servo Mid-Fill– STEP 12

- Remove the nozzle (2) from the body (1)

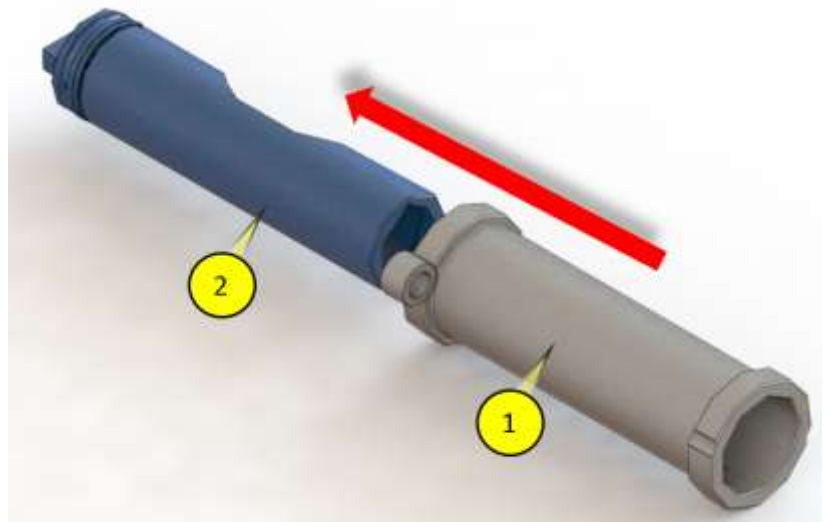

Pressure Valve- Step 13

- Disassemble the pressure relief valve by rotating the cap (1) clockwise.

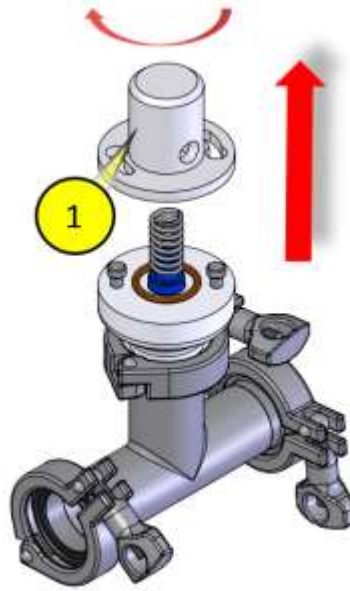

Pressure Valve- Step 14

- Remove the spring(2), clamps (4) piston (1) and holder.(3) .

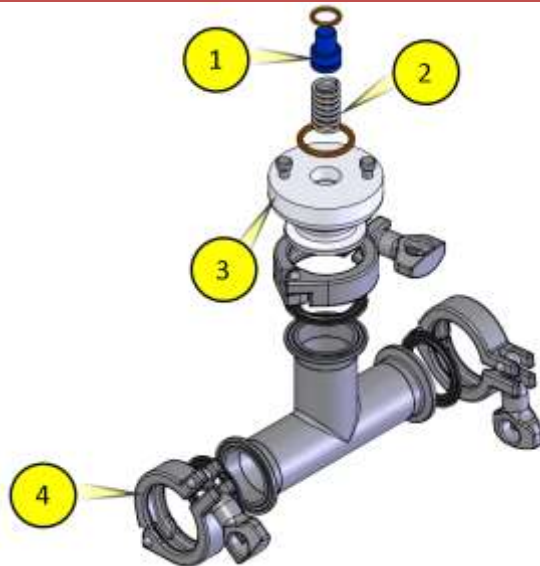

- **NOTE:** Use O-Ring tool to remove all O-Rings



## **Cleaning and Sanitizing**

To assemble the machine follow the steps described in

- For cleaning, use alkaline or neutral cleaners approved by your sanitation chemical supplier for stainless steel, aluminum and other soft metals, painted surfaces, plastics, belts and hoses.
- For Organic Certified applications and other special applications, consult with your sanitation chemical supplier for appropriate cleaners and sanitizers.

## Cleaning and Sanitizing

Clean and sanitize the parts shown, and any attachment parts.

PRO1000si Depositor		<table border="1"> <thead> <tr> <th>#</th> <th>Description</th> </tr> </thead> <tbody> <tr> <td>1</td> <td>Product Cylinder</td> </tr> <tr> <td>2</td> <td>Product Cylinder O Ring</td> </tr> <tr> <td>3</td> <td>Product Piston</td> </tr> <tr> <td>4</td> <td>Product piston O Ring</td> </tr> <tr> <td>5</td> <td>Safe-T-Valve</td> </tr> <tr> <td>6</td> <td>Safe-T-Valve O Ring</td> </tr> <tr> <td>7</td> <td>Clamp</td> </tr> <tr> <td>8</td> <td>Clamp Gasket</td> </tr> <tr> <td>9</td> <td>Safety Pin</td> </tr> <tr> <td>10</td> <td>Safe-T-Valve Block</td> </tr> <tr> <td>11</td> <td>Hopper Gasket</td> </tr> <tr> <td>12</td> <td>Hopper</td> </tr> <tr> <td>13</td> <td>Stirrer Paddle</td> </tr> </tbody> </table>	#	Description	1	Product Cylinder	2	Product Cylinder O Ring	3	Product Piston	4	Product piston O Ring	5	Safe-T-Valve	6	Safe-T-Valve O Ring	7	Clamp	8	Clamp Gasket	9	Safety Pin	10	Safe-T-Valve Block	11	Hopper Gasket	12	Hopper	13	Stirrer Paddle				
		#	Description																															
1	Product Cylinder																																	
2	Product Cylinder O Ring																																	
3	Product Piston																																	
4	Product piston O Ring																																	
5	Safe-T-Valve																																	
6	Safe-T-Valve O Ring																																	
7	Clamp																																	
8	Clamp Gasket																																	
9	Safety Pin																																	
10	Safe-T-Valve Block																																	
11	Hopper Gasket																																	
12	Hopper																																	
13	Stirrer Paddle																																	
Mid-Fill Nozzle		<table border="1"> <thead> <tr> <th>#</th> <th>Description</th> </tr> </thead> <tbody> <tr> <td>1</td> <td>Product hose</td> </tr> <tr> <td>2</td> <td>Gasket</td> </tr> <tr> <td>3</td> <td>Clamp</td> </tr> <tr> <td>4</td> <td>Valve O-Ring</td> </tr> <tr> <td>5</td> <td>Pressure Valve O-Ring</td> </tr> <tr> <td>6</td> <td>Spring</td> </tr> <tr> <td>7</td> <td>Pressure Valve Cap</td> </tr> <tr> <td>8</td> <td>Pressure Valve Insert</td> </tr> <tr> <td>9</td> <td>Pressure Valve O-Ring</td> </tr> <tr> <td>10</td> <td>Valve Body</td> </tr> <tr> <td>11</td> <td>Tee</td> </tr> <tr> <td>12</td> <td>Balancer O-Ring</td> </tr> <tr> <td>13</td> <td>Cap O-Ring</td> </tr> <tr> <td>14</td> <td>End Cap</td> </tr> <tr> <td>15</td> <td>Pressure Valve Body</td> </tr> </tbody> </table>	#	Description	1	Product hose	2	Gasket	3	Clamp	4	Valve O-Ring	5	Pressure Valve O-Ring	6	Spring	7	Pressure Valve Cap	8	Pressure Valve Insert	9	Pressure Valve O-Ring	10	Valve Body	11	Tee	12	Balancer O-Ring	13	Cap O-Ring	14	End Cap	15	Pressure Valve Body
		#	Description																															
1	Product hose																																	
2	Gasket																																	
3	Clamp																																	
4	Valve O-Ring																																	
5	Pressure Valve O-Ring																																	
6	Spring																																	
7	Pressure Valve Cap																																	
8	Pressure Valve Insert																																	
9	Pressure Valve O-Ring																																	
10	Valve Body																																	
11	Tee																																	
12	Balancer O-Ring																																	
13	Cap O-Ring																																	
14	End Cap																																	
15	Pressure Valve Body																																	

## Re Assembly

- Inspect all 'O' rings and seals for damage or wear; replace if required. Re-lubricate all O rings with food quality grease (as supplied with your machine). Re-assemble in the reverse order taking care to align the cutout in the Safe-T-Valve with the mark on the Safe-T-Valve block assembly.

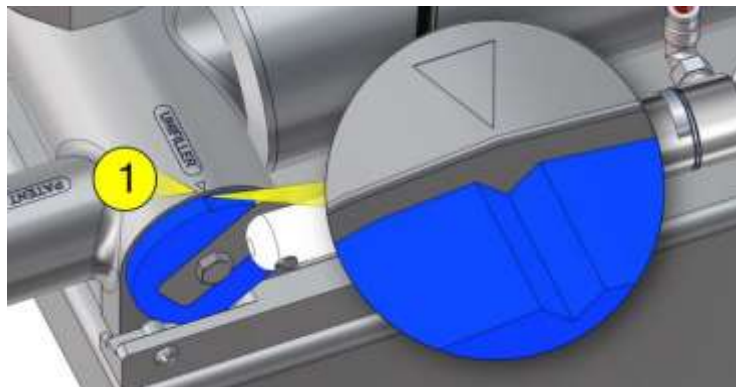

- Re-connect all the airlines
- The rest of the machine can be wiped down or washed with a mild detergent.

## O-Ring and Seals Care

The most important components of the machine are the O-rings. These must be inspected and maintained daily. All O-rings should be high quality Viton as supplied by Unifiller Systems Inc or your authorized Unifiller Systems Inc dealer.

It is highly recommended to carry a complete spare set of O-rings and seals, as these are vital to the accuracy of the machine.

Signs of wear include: Flatness, Abrasions, Cracks, and Cuts

## O-Ring and Seals Part Numbers

Description	Part Number	Quantity Required
Hopper Gasket	01250-00	1
1 1/2" Clamp Gasket	01251-00	1
Safe-T-Valve O Ring	V0223-00	1
Product Cylinder O Ring	V0222-00	1 per Cylinder
1" (25.4 mm) Product Piston O Ring	V0115-00	1 per Piston
1 1/2" (38.1 mm) Product Piston O Ring	V0216-00	1 per Piston
2" (50 mm) Product Piston O Ring	V0223-00	1 per Piston
2 1/2" (63.5 mm) Product Piston O Ring	V0227-00	1 per Piston
3" (76.2 mm) Product Piston O Ring	V0230-00	1 per Piston

The following parts are available from Unifiller Systems Inc or one of its authorized representatives.

Part Number	Description	Item
21052-00	O-ring lubricant.  4 oz tube Lubri-film plus.	
22049-00	O-ring pick tool.	

# Technical Section

## Recipe Backup and Restore

The Unitronics PLC controller in this machine can save up to 100 recipes. The recipes can be backed up and saved to an SD card.

The machine is shipped with an SD memory card inserted and formatted for use with Unitronics PLC. Do not use any other, unformatted SD card.

The SD card can then be used to:

- Back up the recipes to restore them when they do not appear on the PLC screen anymore - due to “memory loss” caused by power spike, welding interference, PLC battery low or accidental battery removal.
- Transfer the backup to another computer or network
- Restore the recipes onto a new PLC controller
- Copy the recipes to a PLC controller in another machine



The SD Card Read and Write Button appears when a SD card is inserted into the back of the operator screen. This allows the *Supervisor or Technician* to backup all of the recipes on to the SD card.

## Backing Up Recipes to the SD Card

Note that when backing up recipes, all saved recipes on the SD card will be overwritten.

To back up recipes:

1. Log in at Supervisor or Technician level
2. Touch the recipe name on operator screen.
3. “Recipe Load” screen will show up.
4. Press the Save icon (floppy disc) in the bottom right corner.
5. “Recipe Save” screen will show up with two grey SD card icons
6. Press the gray SD Card read icon to save all recipes to the SD card
7. After saving is completed (about 1 second), the icon will change color

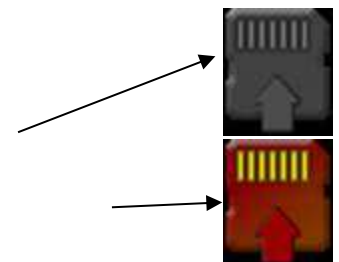

## Restoring all Recipes to the Machine

Note that when restoring recipes, all existing recipes on the machine will be overwritten.

To back up recipes:

1. Log in at Supervisor or Technician level
2. Touch the recipe name on operator screen.
3. "Recipe Load" screen will show up.
4. Press the Save icon (floppy disc) in the bottom right corner.
5. "Recipe Save" screen will show up with two grey SD card icons
6. Press the gray SD Card Write icon to copy all recipes to the machine
7. After copying is completed (about 1 second), the icon will change color

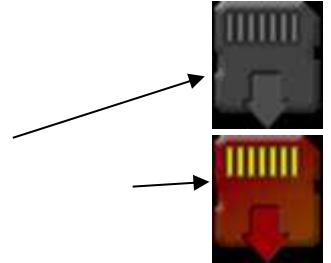

## SD Card Recipe Files

The recipes are stored on the SD Card in the subdirectories DT (Data Tables) with the extension of \*.UDT. These recipe files can only be read by a Unitronics Disk Utility available from the Internet.

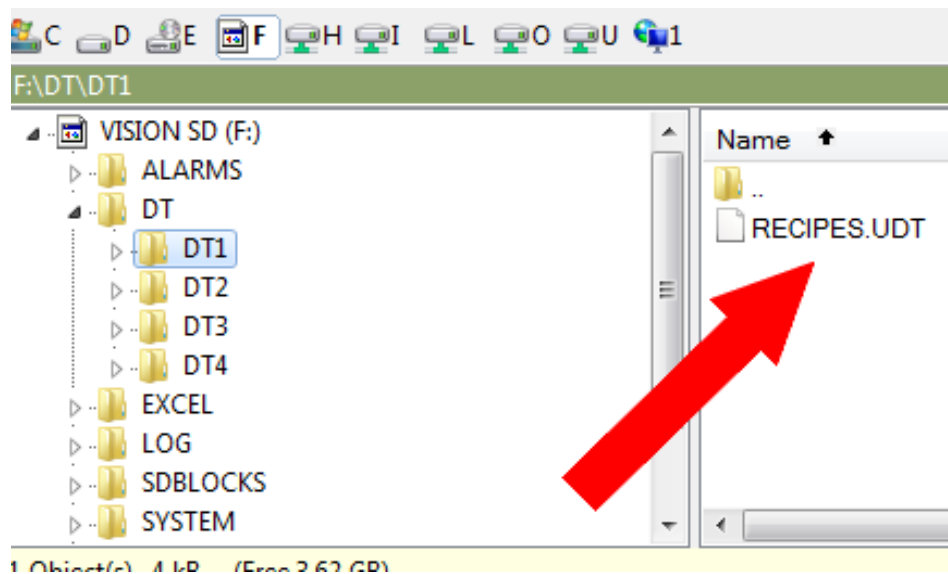

## Belt Adjustment

To adjust the belt follow this procedure:

### To decrease belt tension:

1. Loosen up screw 1 or 2 (or both) on each sides of the conveyor and push the ball nose against the screws
2. Check the alignment and ensure the ball nose is parallel to the edge of the conveyor and adjust if necessary
3. Once adjusted tighten screws 3 and 4.

### To increase belt tension:

1. Loosen up screw 3 or 4 (or both) on each sides of the conveyor and push the ball nose against the screws.
2. Check the alignment and ensure the ball nose is parallel to the edge of the conveyor and adjust if necessary
3. Once adjusted tighten screws 3 and 4.

Note that it is very important to align the ball nose properly with respect to the edge of the conveyor – failure to do so will cause the belt to travel off center of the conveyor.

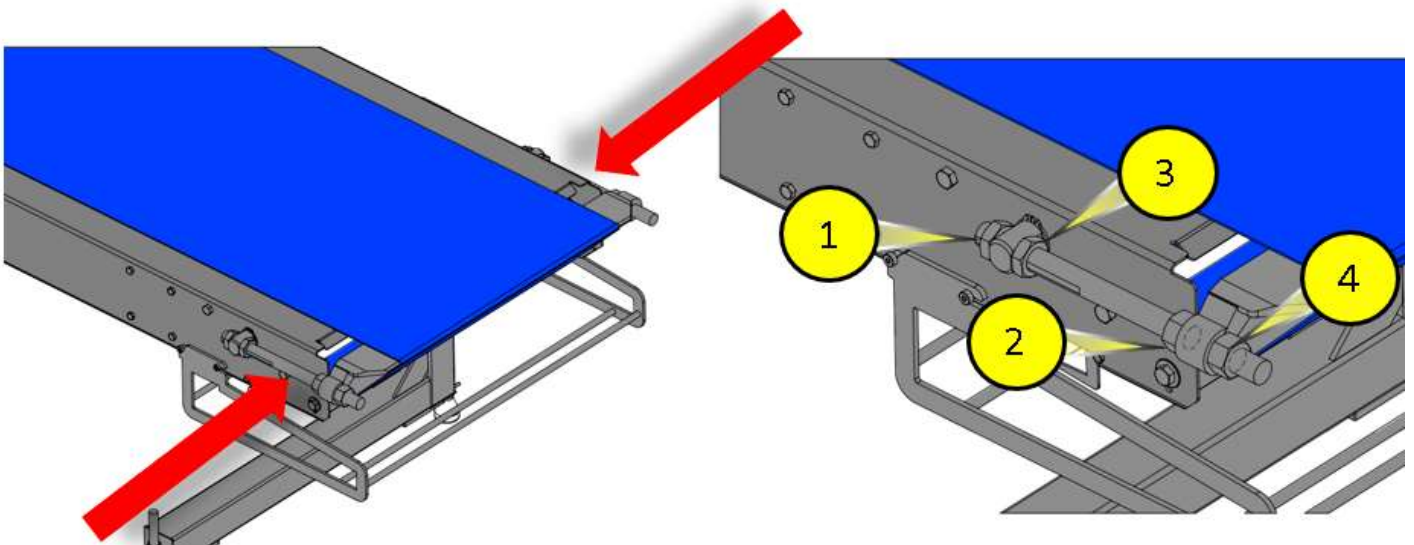

# Preventative Maintenance

Unifiller Systems distinguishes between two levels of care for equipment ‘disassembling’ section in reverse order.

## Machine Owner / Operator Care

The operators of the machines are typically the “owners”, typically a person working with them. They depend on the machine to function reliably to be able to meet their production requirements. They most often know the machine best and can predict when something changes. The owners also typically take care of the basic maintenance and upkeep of the machines.



## Spare Parts Kits

The Spare Parts Kits supplied with the machines are intended for the owners of the machines and are typically kept near the machines in the production area to have easy access to the seals and other wear parts.

## Deluxe Spare Parts Kit

Unifiller also offers Preventative Maintenance Kits for most machines. They are intended for the maintenance department and are typically kept in their workshop. The kits contain all parts for typical repairs and preventative maintenance.

They also contain a USB thumb drive, which contains the manual and other useful information.



The Preventative Maintenance Kits offer a simple and cost effective solution for keeping the machine in top shape.

Contact [parts@unifiller.com](mailto:parts@unifiller.com) with the serial number of your machine to order a Preventative Maintenance Kit or spare parts.



Unplug the machine from power, turn the air off, and remove air supply line from machine before any maintenance is performed.

### IMPORTANT SAFETY NOTES:

Turn air off, and remove supply line from machine before any maintenance is performed.

**Weekly**

Check the air filter/regulator bowl and if necessary clean the bowl and empty any accumulated water.

**3 Months**

Check the condition of the white filter in the Air regulator / Water filter, and replace if contaminated.

**3 Years, 6000 hours or 7 Million Cycles**

Re-grease the Exlar actuator as described in the section below.

# Exlar Linear Servo Drive Maintenance

The Exlar linear servo unit is a very reliable, high quality component that drives the product pistons in the PRO1000siSV. It does, however, require a minimum of the following preventative maintenance task:

## **Roller Screw Lubrication Grease Replacement**

Exlar recommends that you use Mobilith SHC 220 grease (high performance, extreme pressure) [http://www.mobilindustrial.com/ind/english/products\\_greases\\_mobilith-shc-grease-series.aspx](http://www.mobilindustrial.com/ind/english/products_greases_mobilith-shc-grease-series.aspx)

The roller screw of the Exlar linear servo unit requires periodic inspection and renewal of the grease on the roller screw. Exlar recommends that you do this every 3 years, 6000 hours or 7 million cycles.

Below is the procedure for replacing the lubrication grease on the roller screw:

1. Remove the Exlar unit from the machine
2. Remove the four tie rod nuts from the back of the actuator
3. Remove the roller screw by turning it counter-clockwise and threading it out of the cylinder (it may be necessary to keep the roller screw cylinder from turning to remove the screw).
4. Apply a coating of grease to the angular contact thrust bearings, roller screw cylinder and roller screw assembly. Do not pack the components with grease, excessive grease requires more torque of the unit and does not improve the lubrication of the unit).
5. Use a brush to work approximately 0.5 cu inch of grease for every 3 inches of stroke length into the roller screw cylinder. Be sure to cover all threaded surfaces of the screw assembly. Rotate the components repeatedly in both direction to work the grease into the assembly.
6. Force grease into the front of the thrust bearing assembly. Grease must reach the bearing just behind the bearing that is visible as well. Use 0.75 cu inch of grease.
7. Rethread the roller screw into the internally threaded cylinder (do not force the roller screw into the cylinder). It is best to have the actuator vertical for this operation.

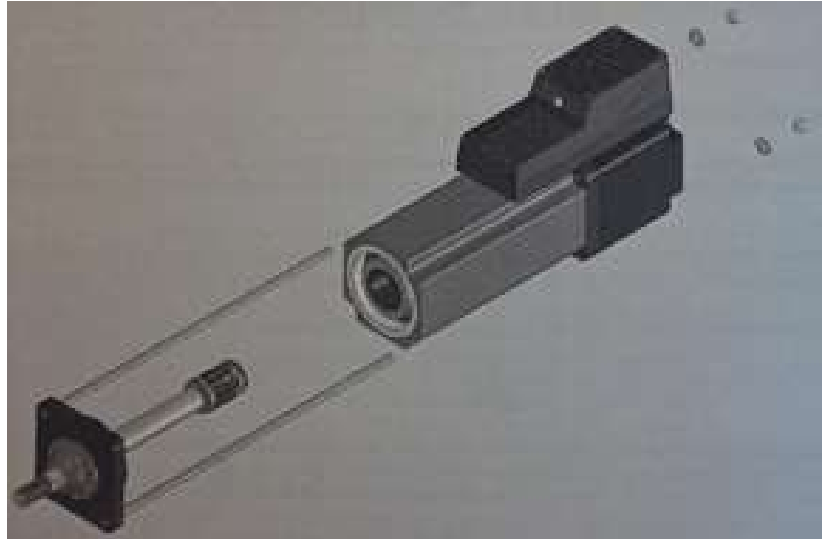

# Troubleshooting

## Machine will not Cycle

- Check main air supply for pressure
- E-stop is pressed
- Volume adjustment set too low
- Incomplete piston stroke due an obstruction or really thick product
- Product being deposited is too hot and the valve is seizing.
- Check parameter values
- Load a different recipe and test if problems occurs from abnormal parameter values

## Inconsistent Deposit

- Air leakage past product cylinder piston or rotary valve – check O-rings
- Hopper is empty and sucking in air
- Product is very airy and has large air pockets
- Piston recharge speed is too fast stretching the product and creating a void
- Product is too thick for the depositor and product speed is set too high causing the pistons too stall
- Water build up in airlines and valves
- Hopper is not secured tight. Adjust the hopper lock handle

.....



# Mechanical Spare Parts

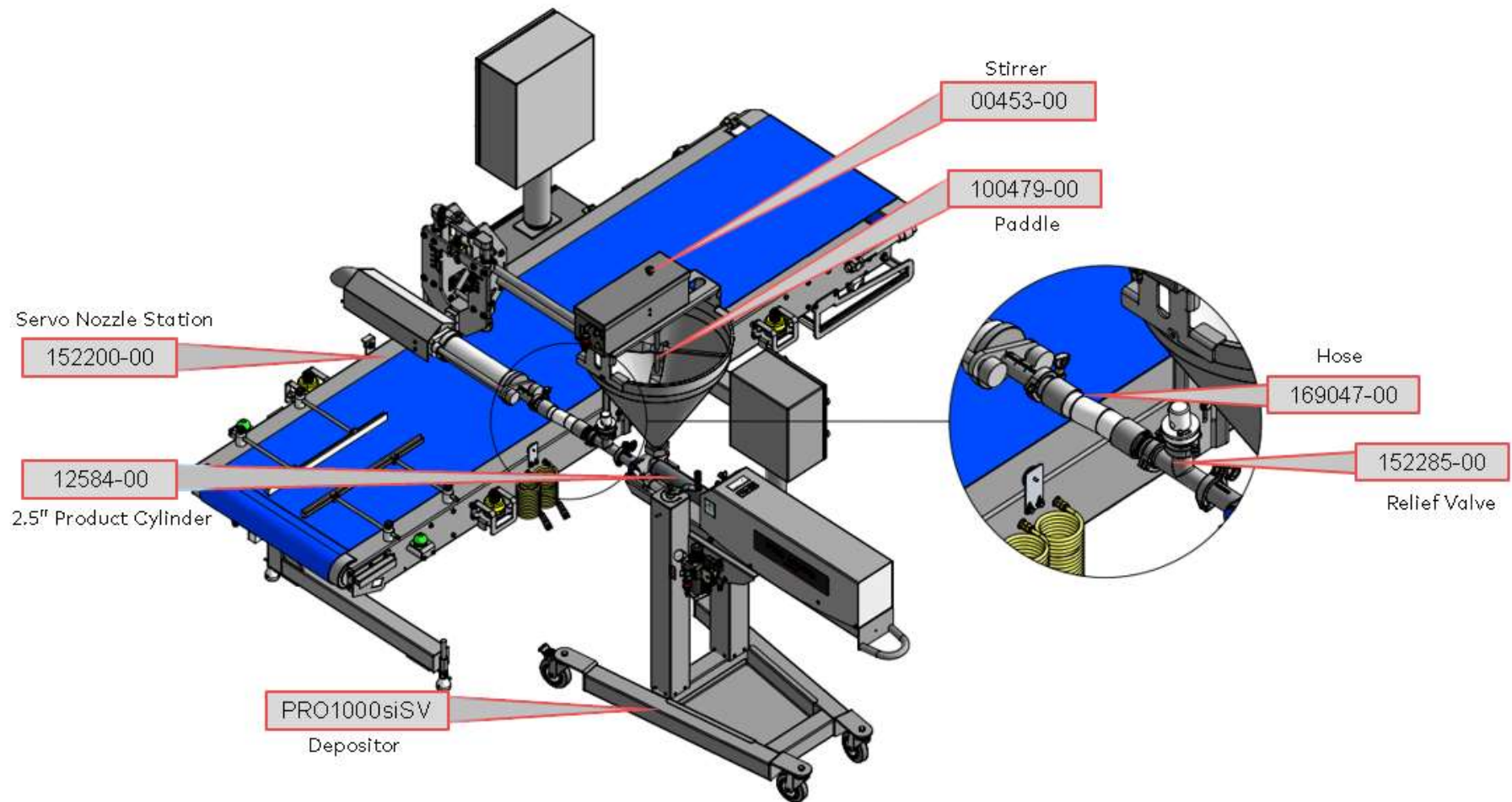

Part Number	Description
00453-00	SUBASS STIRRER BOX COMPLETE
100479-00	STIRRER PADDLE 14 GAL / 52 LTR
12584-00	UNI 1000I 2.5" PRODUCT CYLINDER KIT
152200-00	SUBASS SERVO NZL STAT
152285-00	SUBASS PRESSURE RELIEF VALVE
169047-00	SUBASS PRODUCT HOSE 1.5" X 18"
PRO1000siSV-EU	MA PRO 1000SISV SERVO

152285-00

Pressure Relief Valve

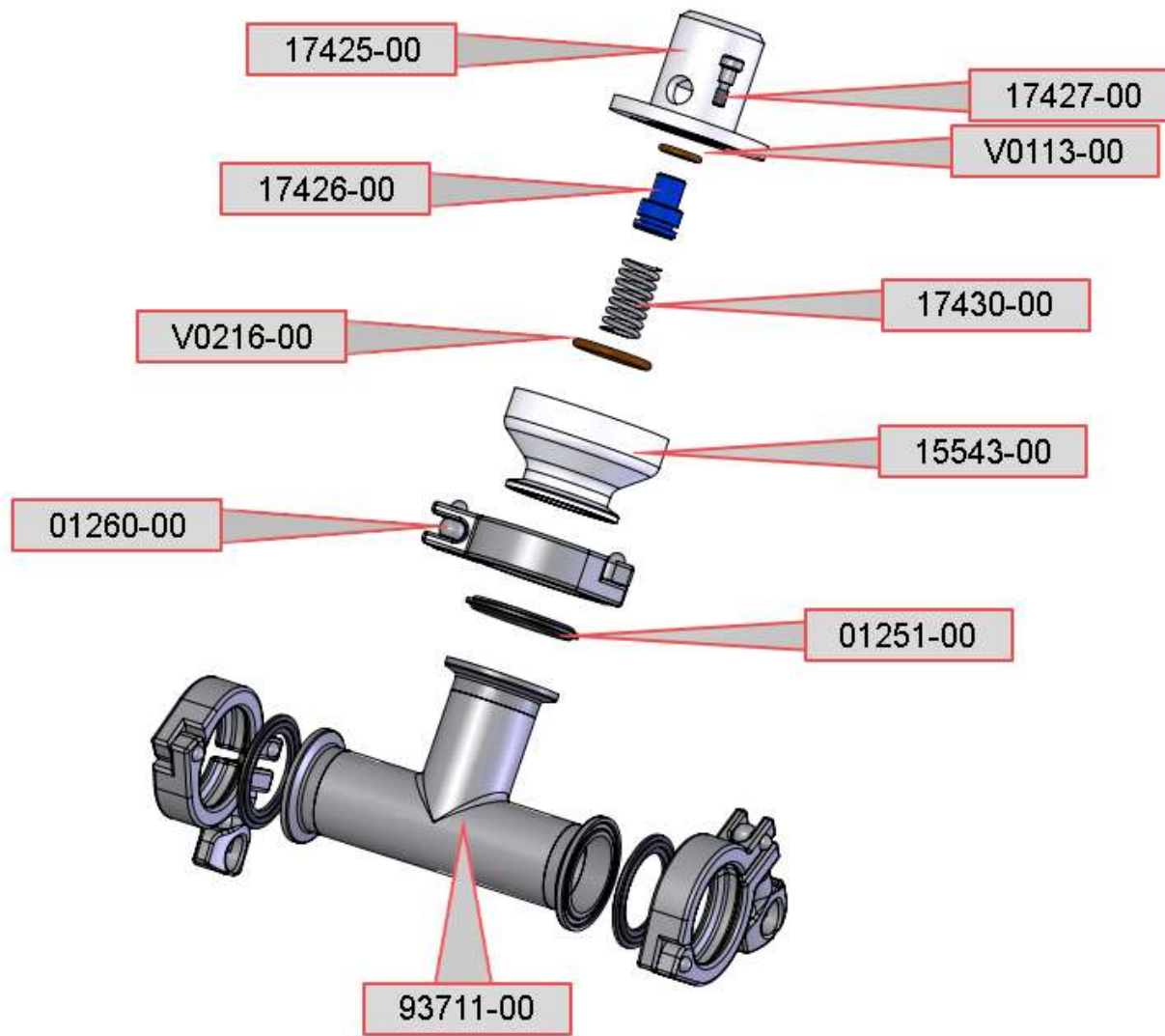

Part Number	Description
01251-00	GASKET TRICLAMP 1.5
01260-00	CLAMP CAST 1-1/2"
15543-00	BLOCK PRESS RELIEF 1000Si
17425-00	CAP PRESSURE VALVE
17426-00	PISTON PRESSURE RELIEF
17427-00	COVER PIN
17430-00	SPRING - 1.25 LONG
93711-00	TEE 1.5" WITH FERRULES WELDED
V0113-00	O-RING FOOD SERVICE 113
V0216-00	O-RING FOOD SERVICE 216

152200-00

Pressure Relief Valve

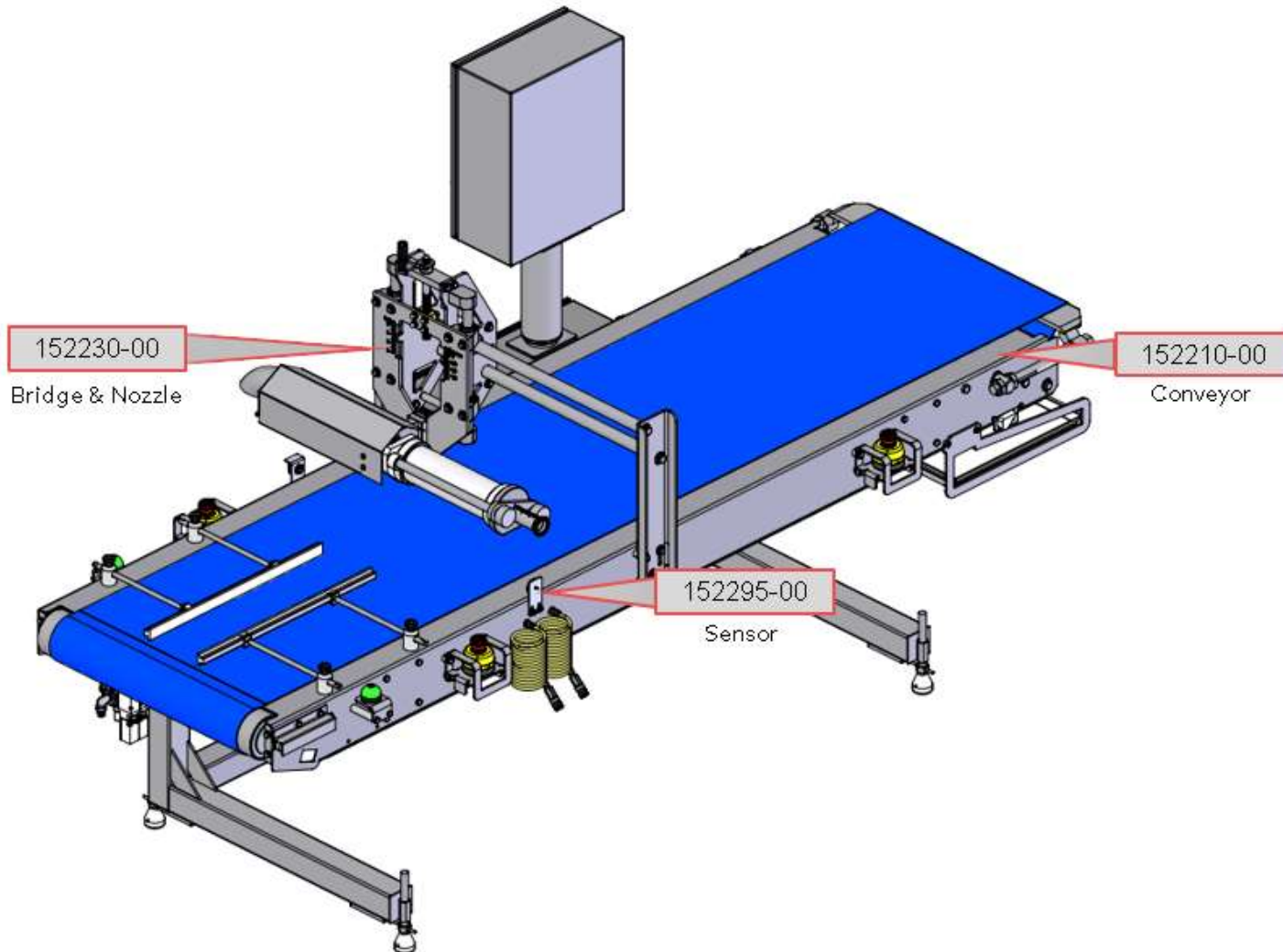

Part Number	Description
152210-00	SUBASS CONVEYOR SRV NZL
152230-00	SUBASS SERVO NOZZLE FULL
152295-00	SUBASS RELFECTIVE SENSOR

152210-00

Ball Nose Conveyor Sub-Assembly

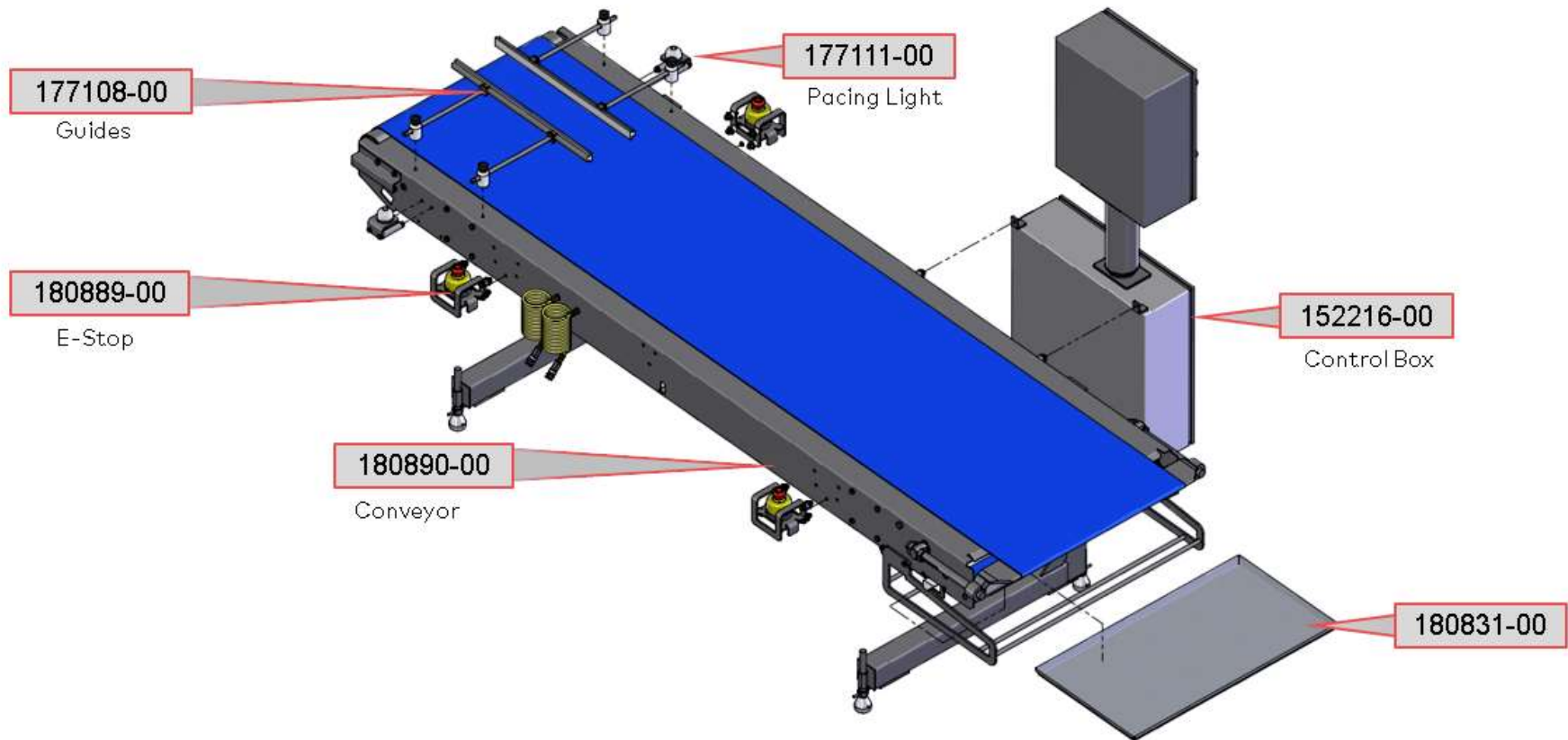

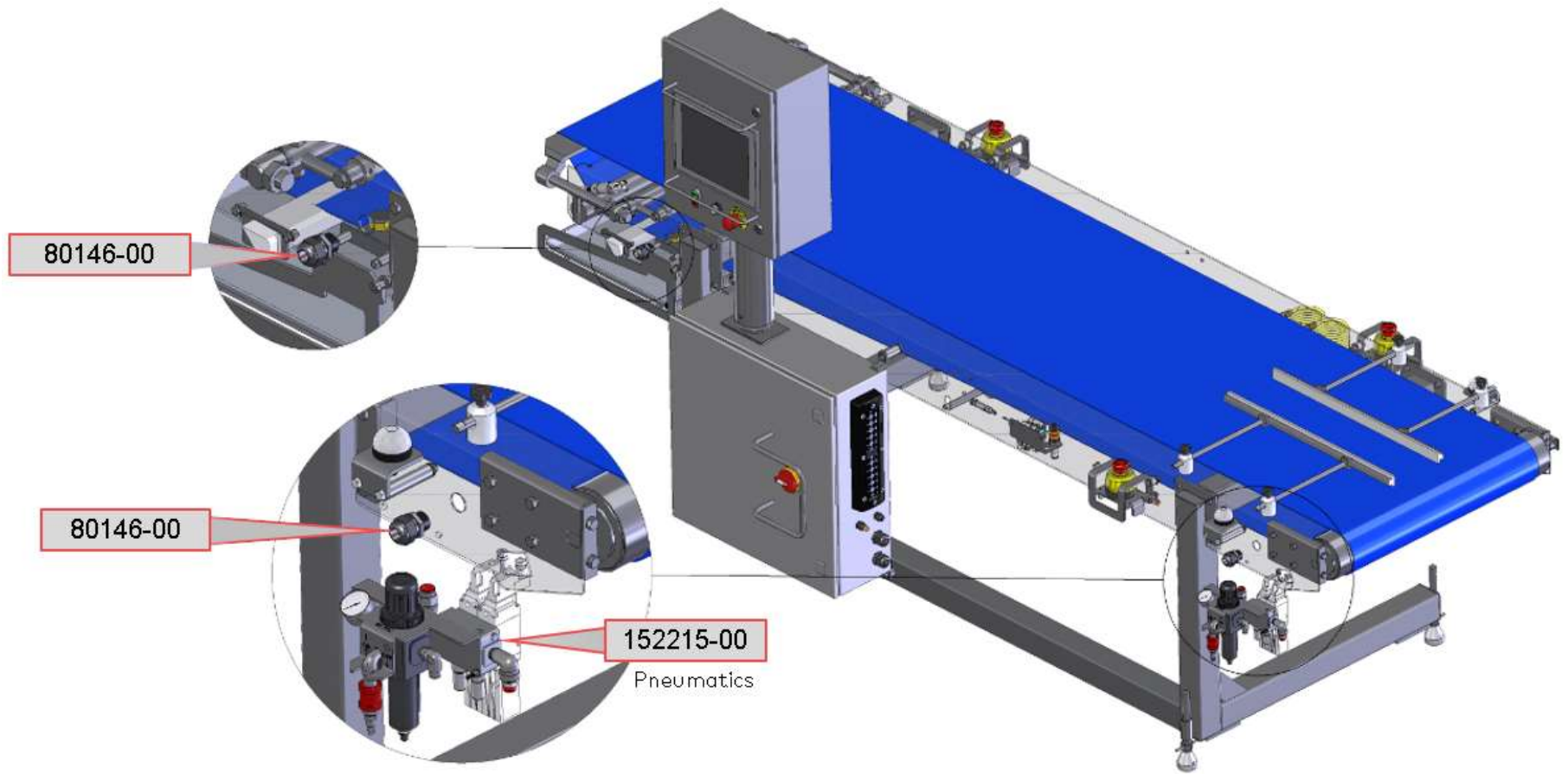

Part Number	Description
152215-00	SUBASS SRV MID-FILL PENU CAT 3
152216-00	SUBASS CTRL BOX MID-FILL SRV NZL
177108-00	SUBASS GUIDES LONG CONV
177111-00	SUBASS TOUCH BUTTON CONV
180831-00	TRAY SHEET PAN 32.7L 17.7W .063 AL
180889-00	SUBASS CONVEYOR SRV NZL BL NO
180898-00	MA SBC 10FT 26.0W BLT 32.63W BL NO
80146-00	ELECCOMP 3/4" STRAIN RELIEF
180890-00	

152295-00

Sensor Sub-assembly

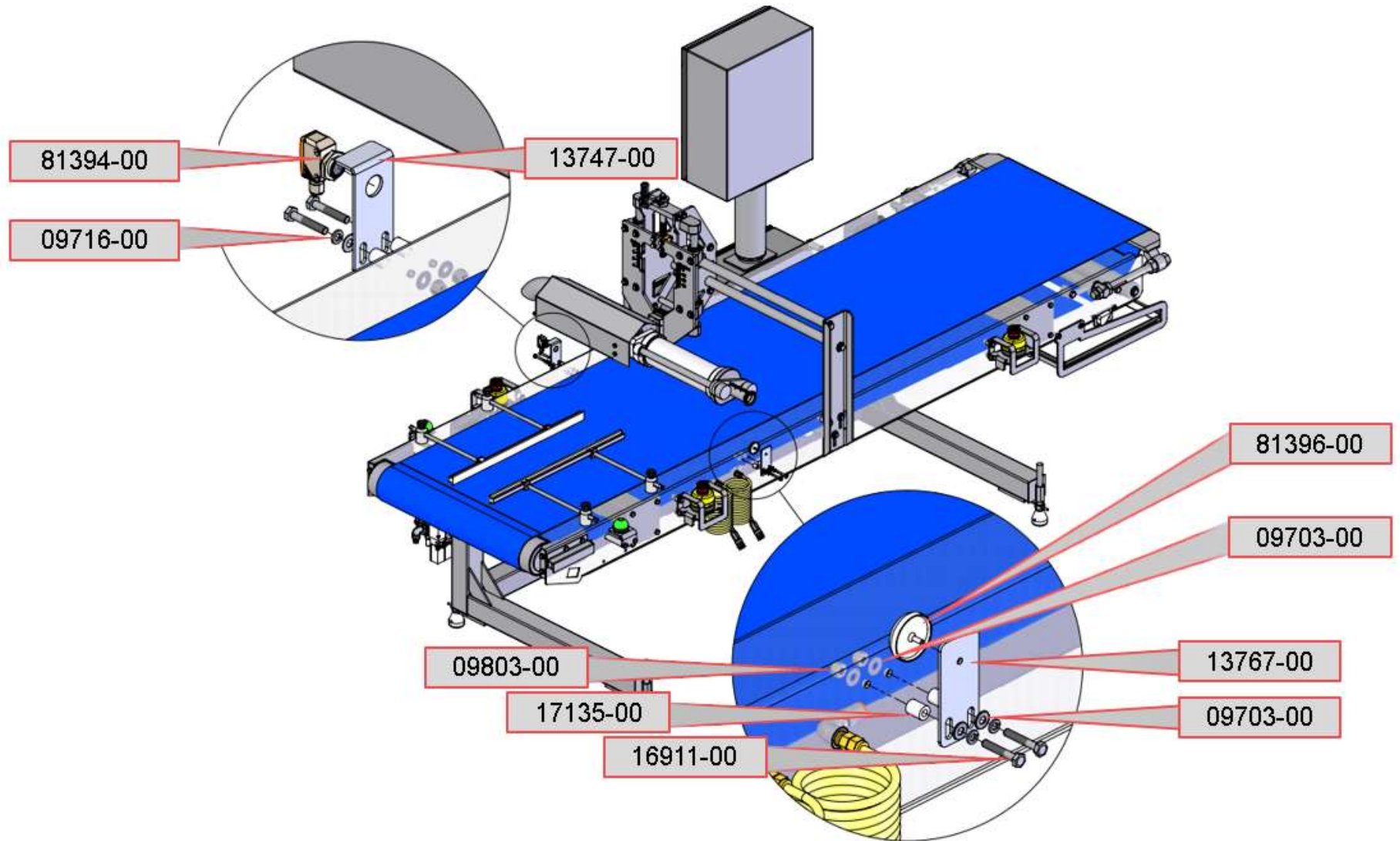

Part Number	Description
09703-00	WASHER FLAT 1/4
09716-00	WASHER LOCK 1/4
09803-00	FAST NUT NYLOC 1/4-20
13747-00	MOUNT, SENSOR, CONVEYOR
13767-00	MOUNT, REFLECTOR, CONVEYOR
16911-00	FAST HEX CAP 1/4-20 X 1-1/2
17135-00	SPACER 1/2 X 1/4 X .625
81394-00	SENSOR IFM REFLECTIVE 4M
81396-00	SENSOR IFM REFLECTOR 40MM DIA

180890-00

### LHS Ball Nose Conveyor

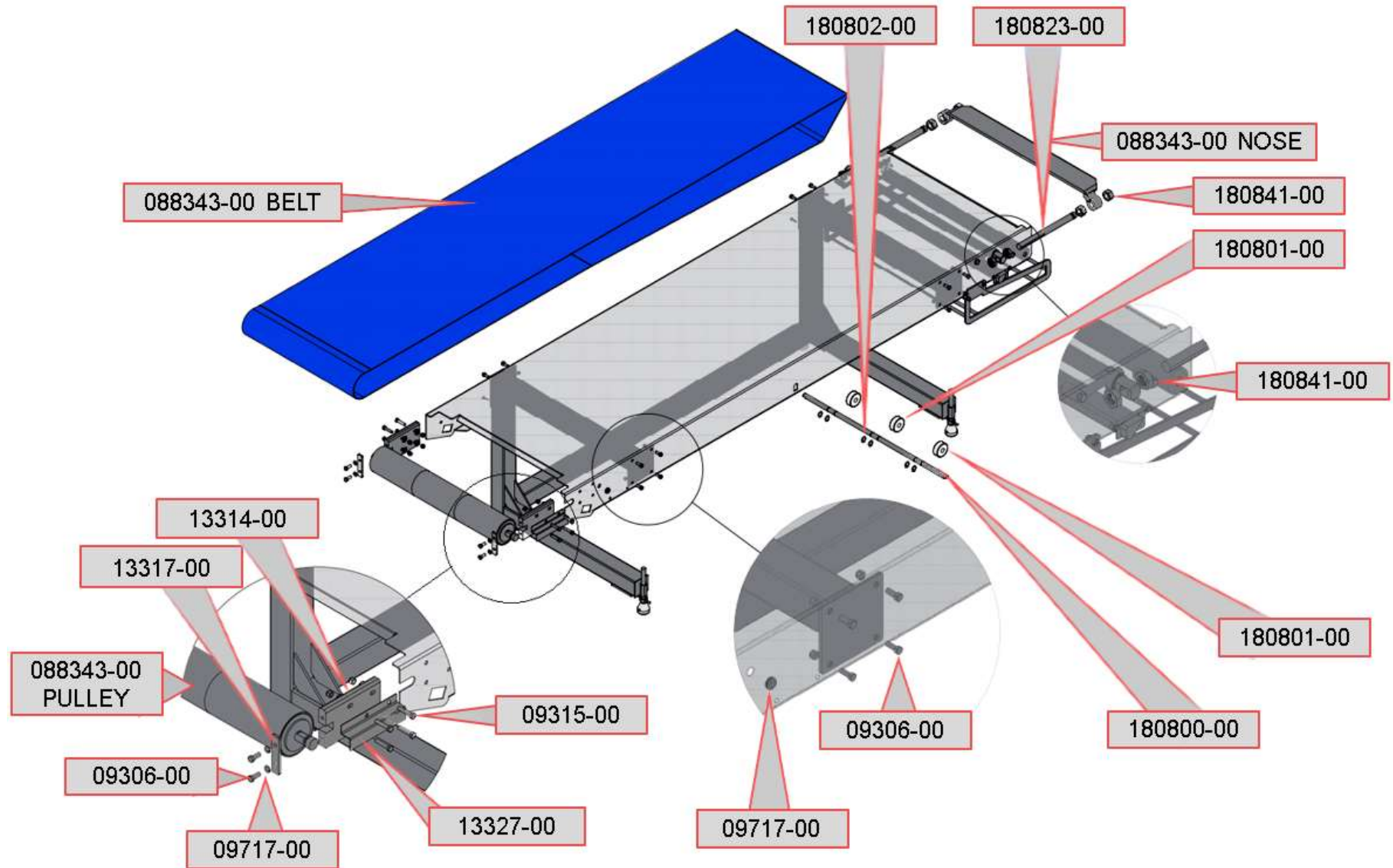

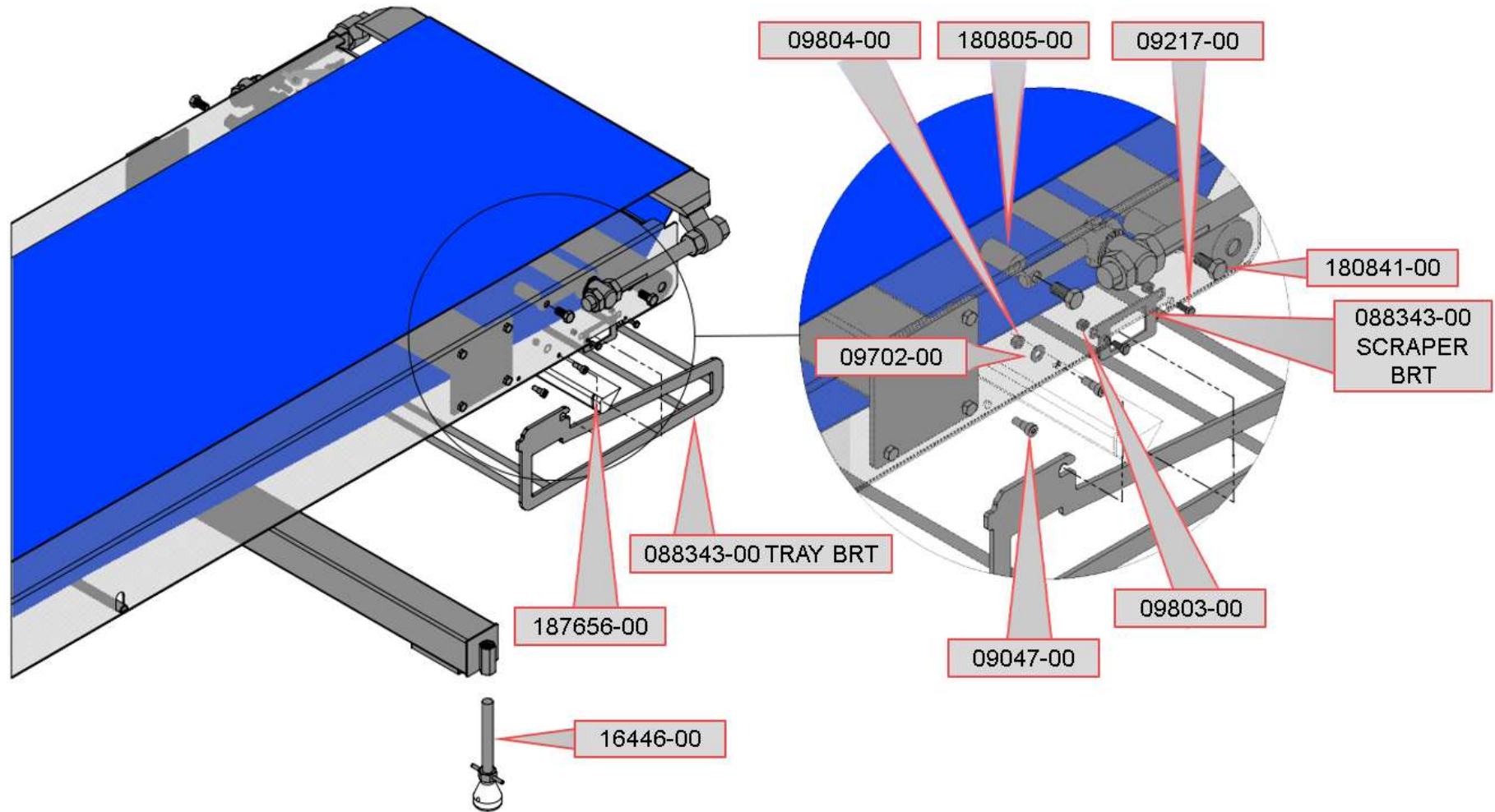

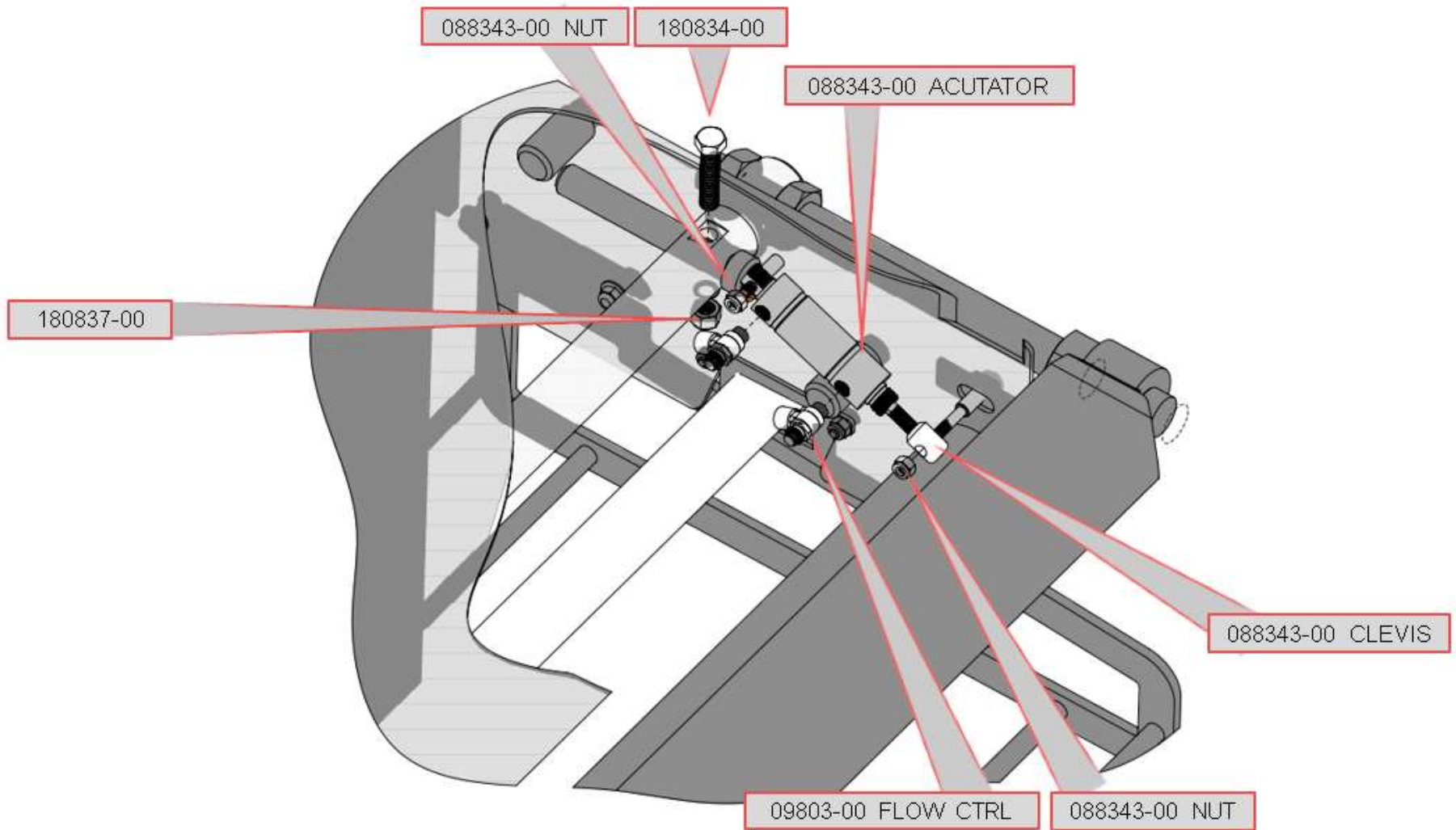

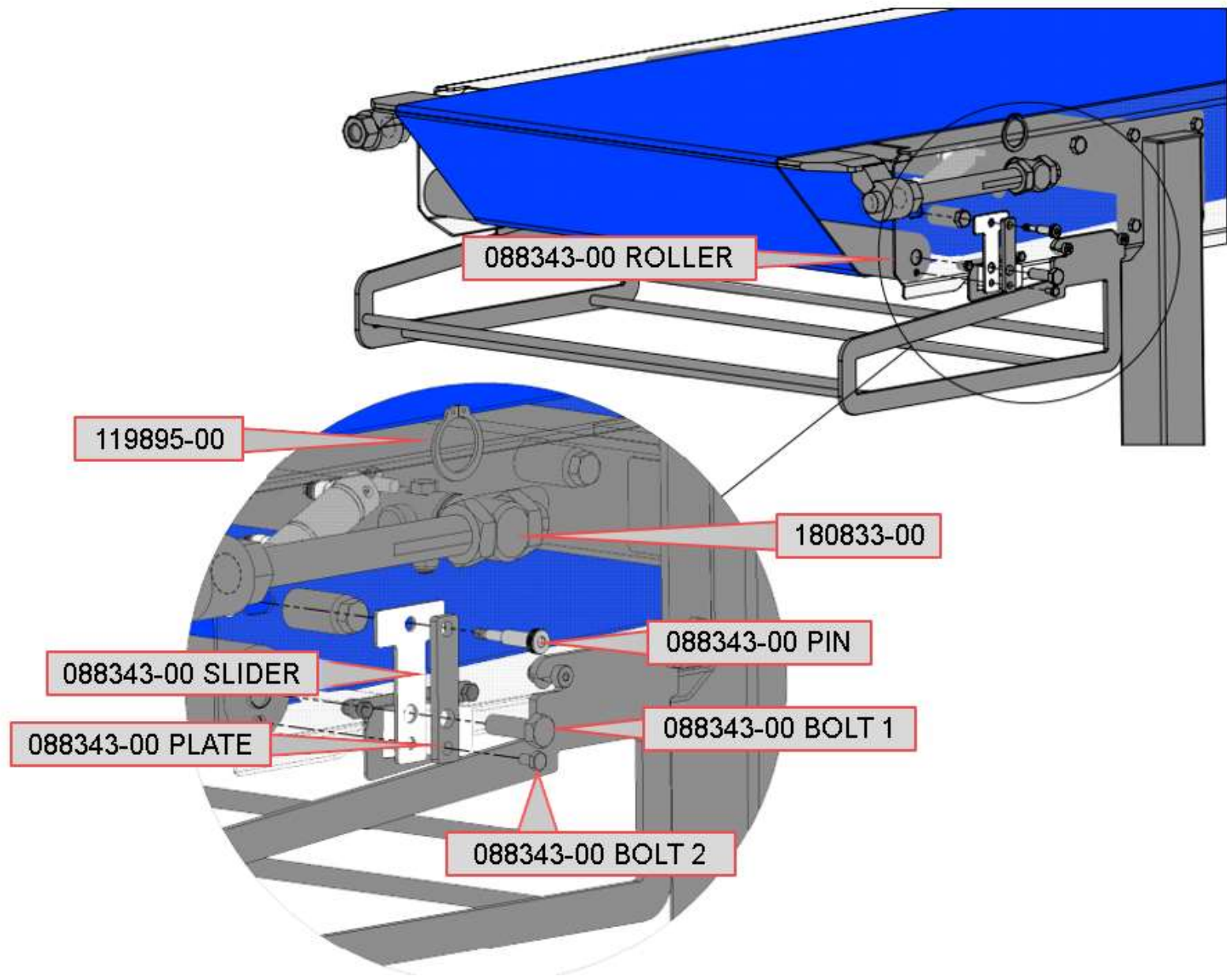

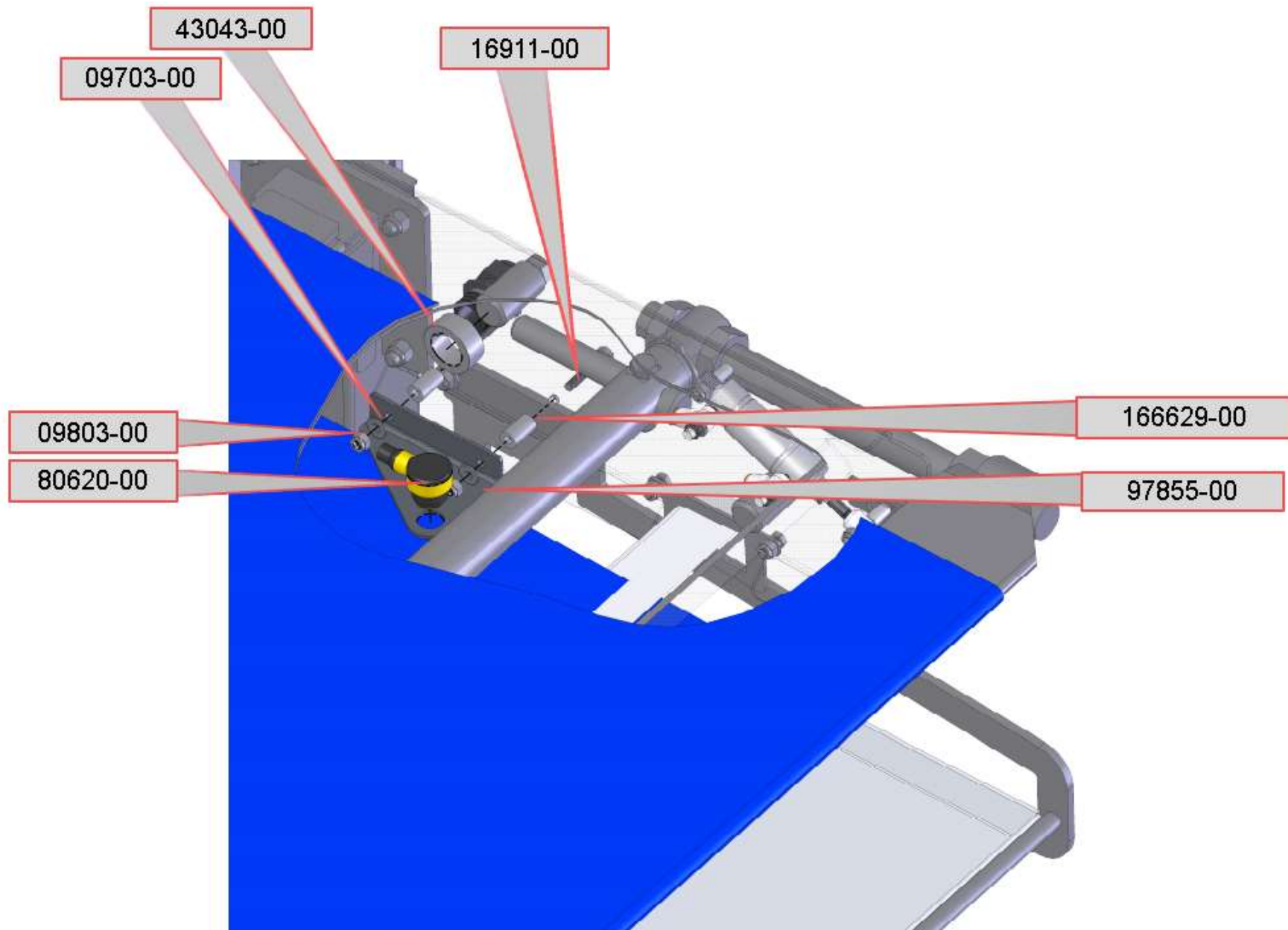

Part Number	Description
088343-00 ACTUATOR	AIR ACTUATOR
088343-00 BELT	SANITARY BELT
088343-00 BOLT 1	
088343-00 BOLT 2	
088343-00 CLEVIS	ACTUATOR CLEVIS
088343-00 NOSE	PLATE NOSE
088343-00 NUT	HEX NUT
088343-00 NUT	HEX NUT
088343-00 PIN	PIN
088343-00 PLATE	PRESSURE PLATE
088343-00 PULLEY	ROLLER PULLEY
088343-00 ROLLER	TRACKING ROLLER
088343-00 SCRAPER BRT	SCAPER BRACKET
088343-00 SLIDER	TRACKING MECH SLIDER
088343-00 TRAY BRT	TRAY BRACKET
09047-00	FAST SKT SHLDR 5/16-18 X 3/8 X 3/8
09217-00	FAST HEX CAP 1/4-20 X 5/8
09306-00	FAST HEX CAP 3/8-16 X 1
09315-00	FAST HEX CAP 3/8-16 X 1-3/4
09702-00	WASHER FLAT 5/16
09703-00	WASHER FLAT 1/4
09717-00	WASHER LOCK 3/8
09803-00	FAST NUT NYLOC 1/4-20
09803-00 FLOW CTRL	
09804-00	FAST NUT NYLOC 5/16-18
119895-00	RING SNAP 1.5 EXTERNAL
13314-00	BLOCK MOTORIZED PULLEY MOUNT
13317-00	PLATE MOTOR MOUNT
13327-00	GUARD MOTOR CONNECTOR
16446-00	FOOT ADJUSTABLE DELRIN ASSY LONG
166629-00	SPACER .500OD .252ID .875L
16911-00	FAST HEX CAP 1/4-20 X 1-1/2
180800-00	ROD 0.75OD 33.44L BELT ROLLER
180801-00	SPACER WHEEL STANDARD CONV
180802-00	RING SNAP 0.75" EXTERNAL
180805-00	SHAFT 1.00D LIMIT ROLLER 6FT CONV
180823-00	SUBCOMP IDLER HOLDER WELD 10FT CONV
180833-00	SHAFT 1.50OD 36.5L CONV TILT PULLEY
180834-00	FAST HEX CAP 7/16-14 X 2
180837-00	FAST NUT NYLOC 7/16-14
180841-00	FAST NUT JAM 1-8
187656-00	SCRAPER BELT CFAME 32.63W

43043-00	COLLAR SET 1.00" S/S
80620-00	SENSOR FIXED FIELD 100 MM 4PIN
97855-00	BRACKET PHOTOCELL L.H. DECO. LINE

180890-00

E-Stop Assembly

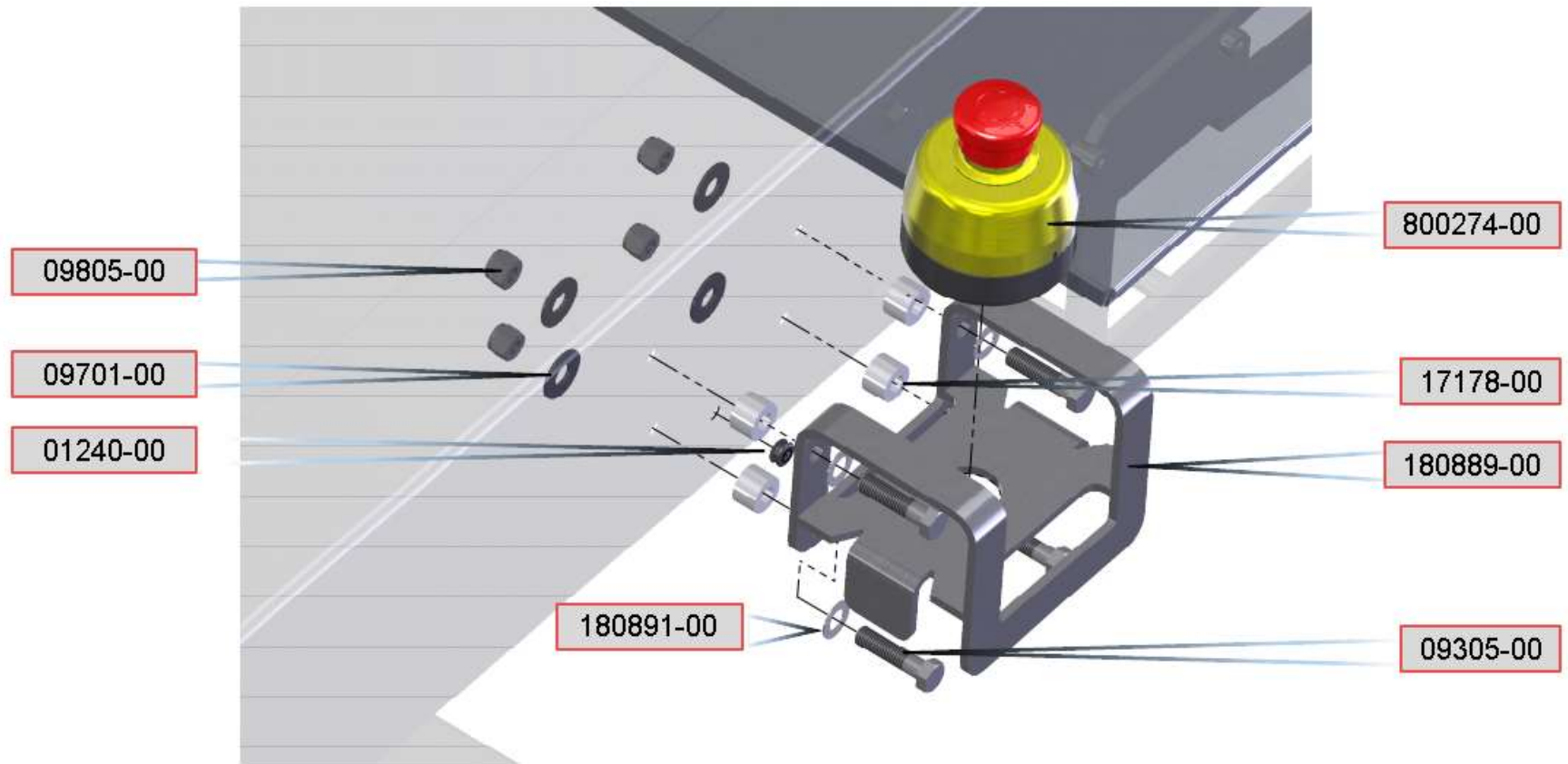

Part Number	Description
01240-00	GROMMET 0.79ID 0.125 GROOVE RUBBER
09305-00	FAST HEX CAP 3/8-16 X 1-1/2
09701-00	WASHER FLAT 3/8
09805-00	FAST NUT NYLOC 3/8
17178-00	SPACER 3/4 X 3/8 X .5 - SS
180889-00	BRACKET E-STOP DUAL
180891-00	WASHER FLAT .406ID .75OD .06T
800274-00	BUTTON E-STOP RED 1NO/2NC

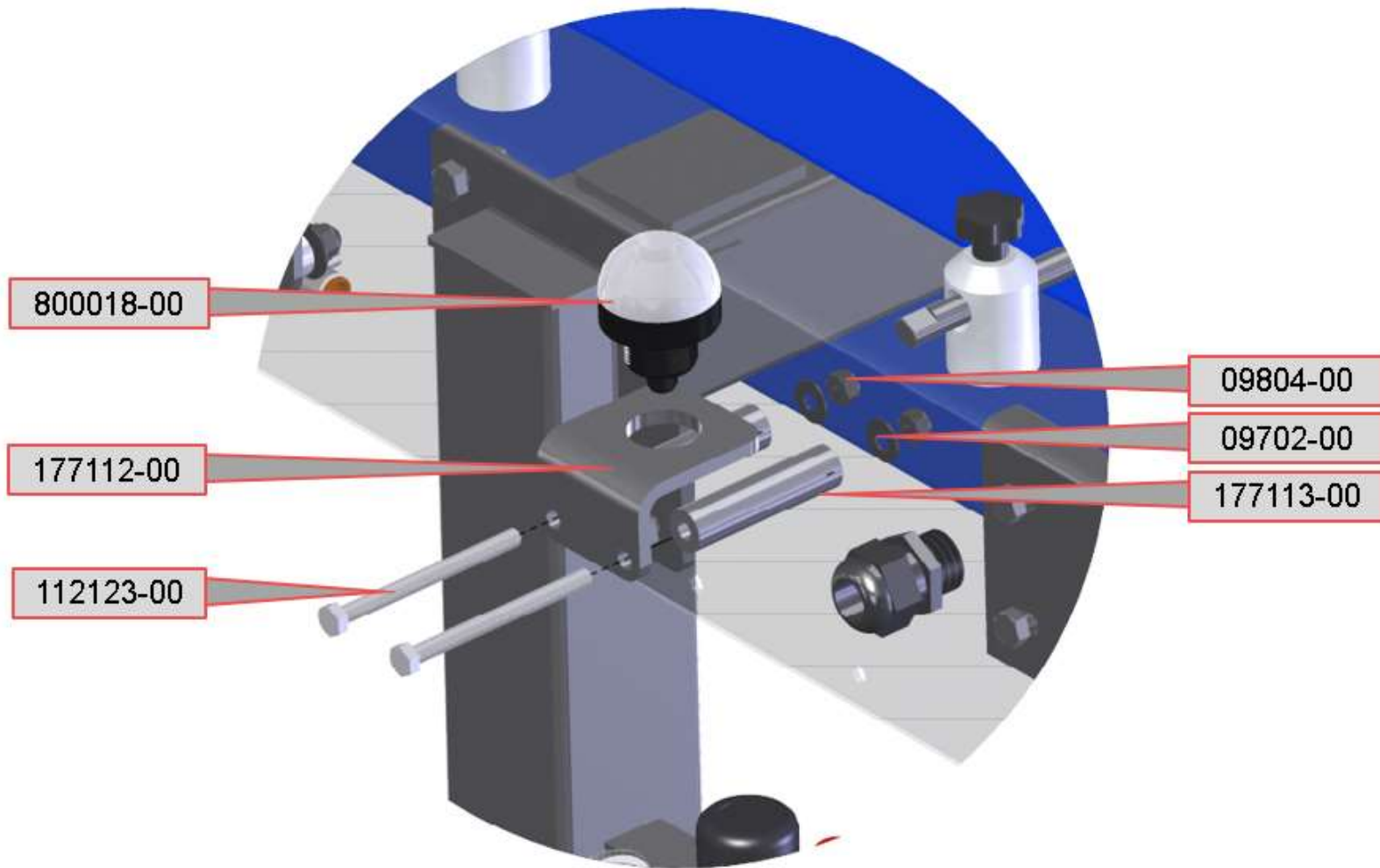

Part Number	Description
09702-00	WASHER FLAT 5/16
09804-00	FAST NUT NYLOC 5/16-18
112123-00	FAST HEX CAP 5/16-18 X 3-3/4
177112-00	BRACKET TOUCH BUTTON CONV
177113-00	SPACER .75OD .315ID 3L
800018-00	BUTTON TOUCH LED DOME GRN/RED/YEL

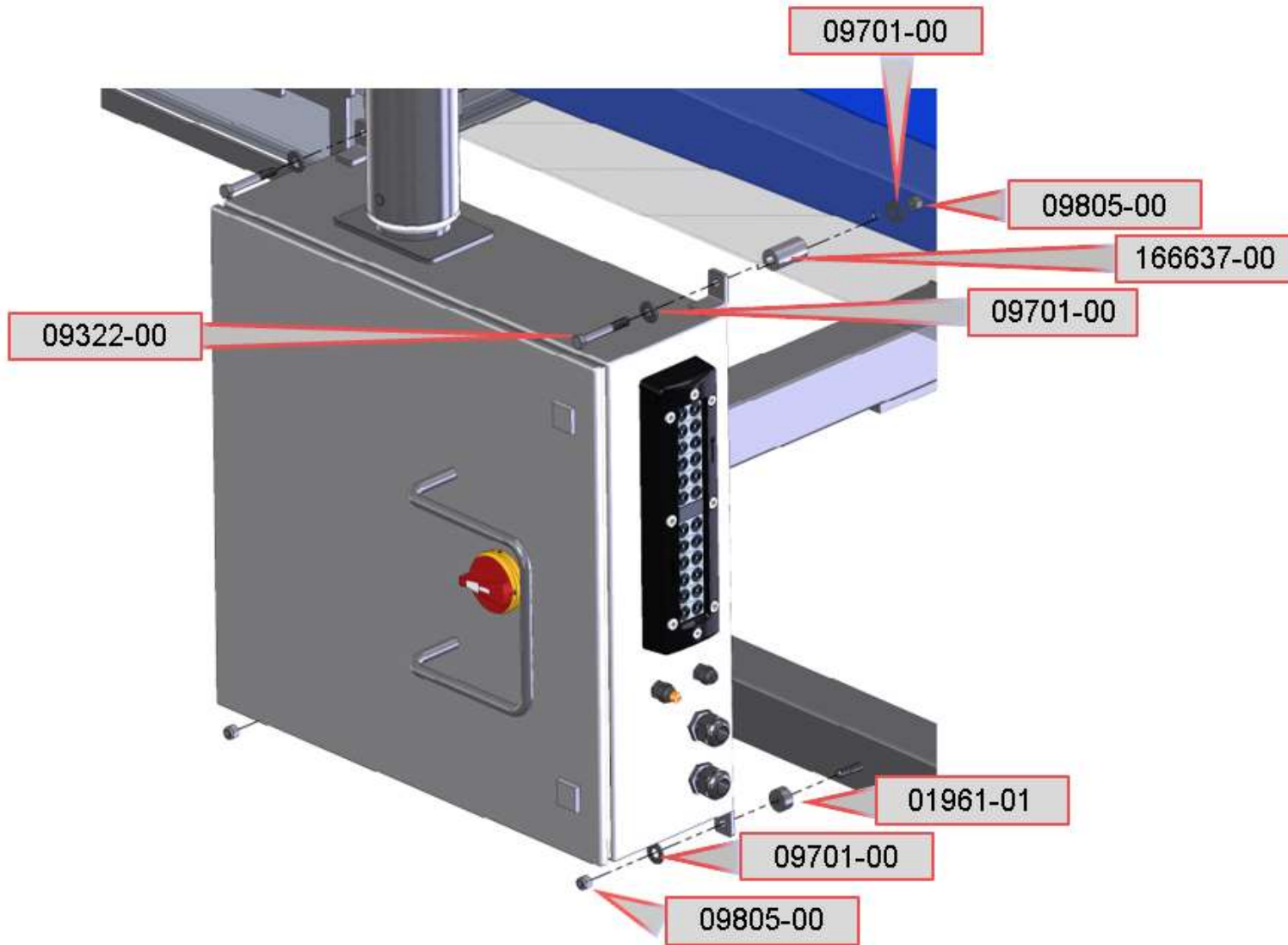

Part Number	Description
01961-01	SPACER 1.0 X .5 - 3/8-16
09322-00	FAST HEX CAP 3/8-16 X 2-3/4
09701-00	WASHER FLAT 3/8
09805-00	FAST NUT NYLOC 3/8
166637-00	SPACER 1.0OD .505ID 1.75L

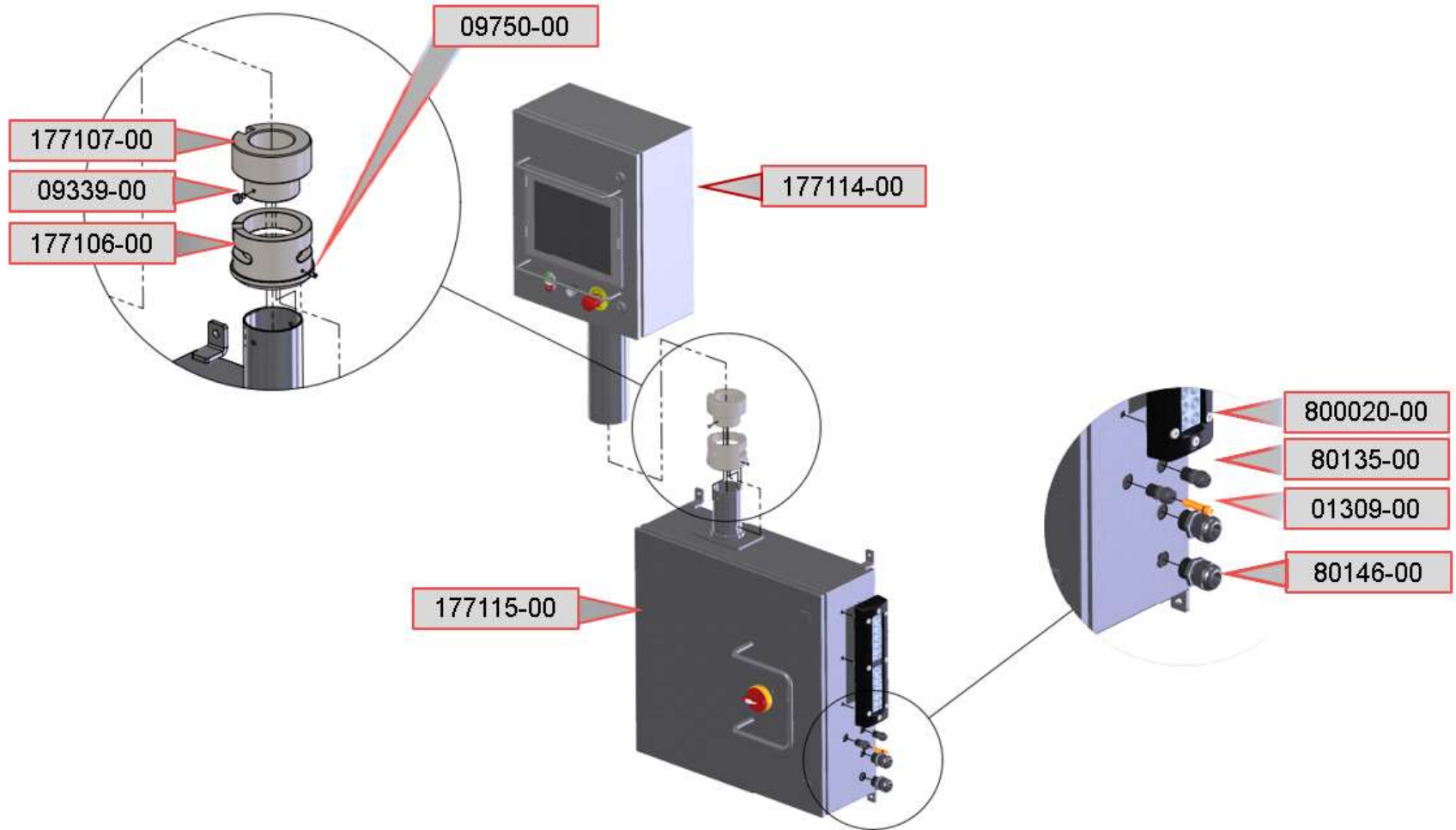

Part Number	Description
01309-00	AIRFTG PLUG 3/8
09339-00	FAST HEX CAP 1/4-20 X 3/8
09750-00	09750-00
177106-00	BRACKET POST BUSH SV NZL BOT
177107-00	BRACKET POST BUSH SV NZL TOP
177114-00	SUBASS ENCLOSURE UPPER SERVO SYS
177115-00	SUBASS ENCLOSURE LOWER SERVO SYS
800020-00	ROX EZENTRY 24/24 SS FAST
80135-00	ELECCOMP 3/8" STRAIN RELIEF
80146-00	ELECCOMP 3/4" STRAIN RELIEF

152210-00

Bridge & Nozzle

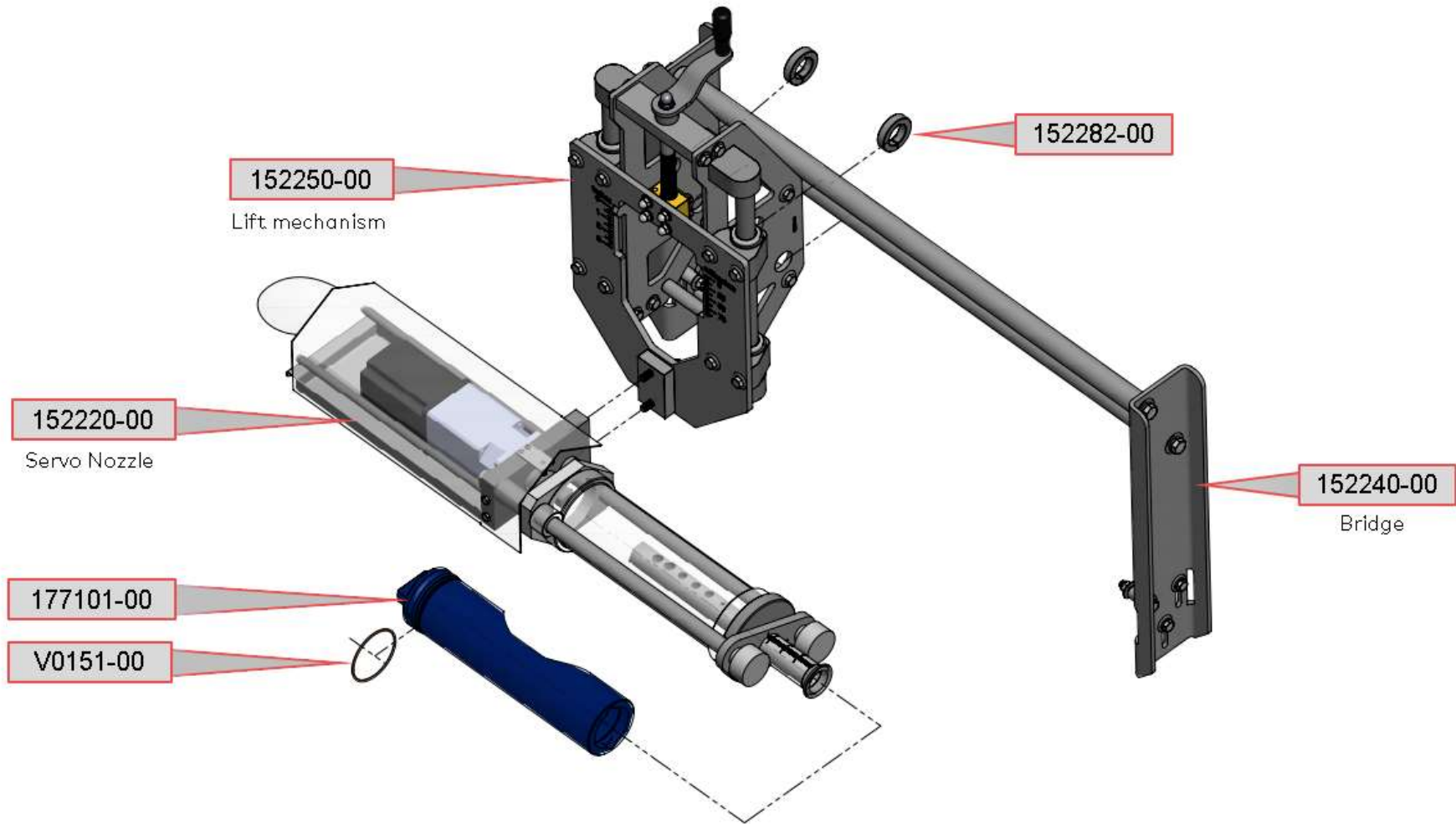

Part Number	Description
152220-00	SUBASS MID-FILL SRV NZL BODY
152240-00	SUBASS MID-FILL SRV NZL BRIDGE
152250-00	SUBASS SRV NZL LIFT MECH
152282-00	COLLAR SET 1.25ID 2.063OD .5T
177101-00	VALVE 3.4OD D PROF FLT SERVO SPRD
V0151-00	O-RING FOOD SERVICE 151

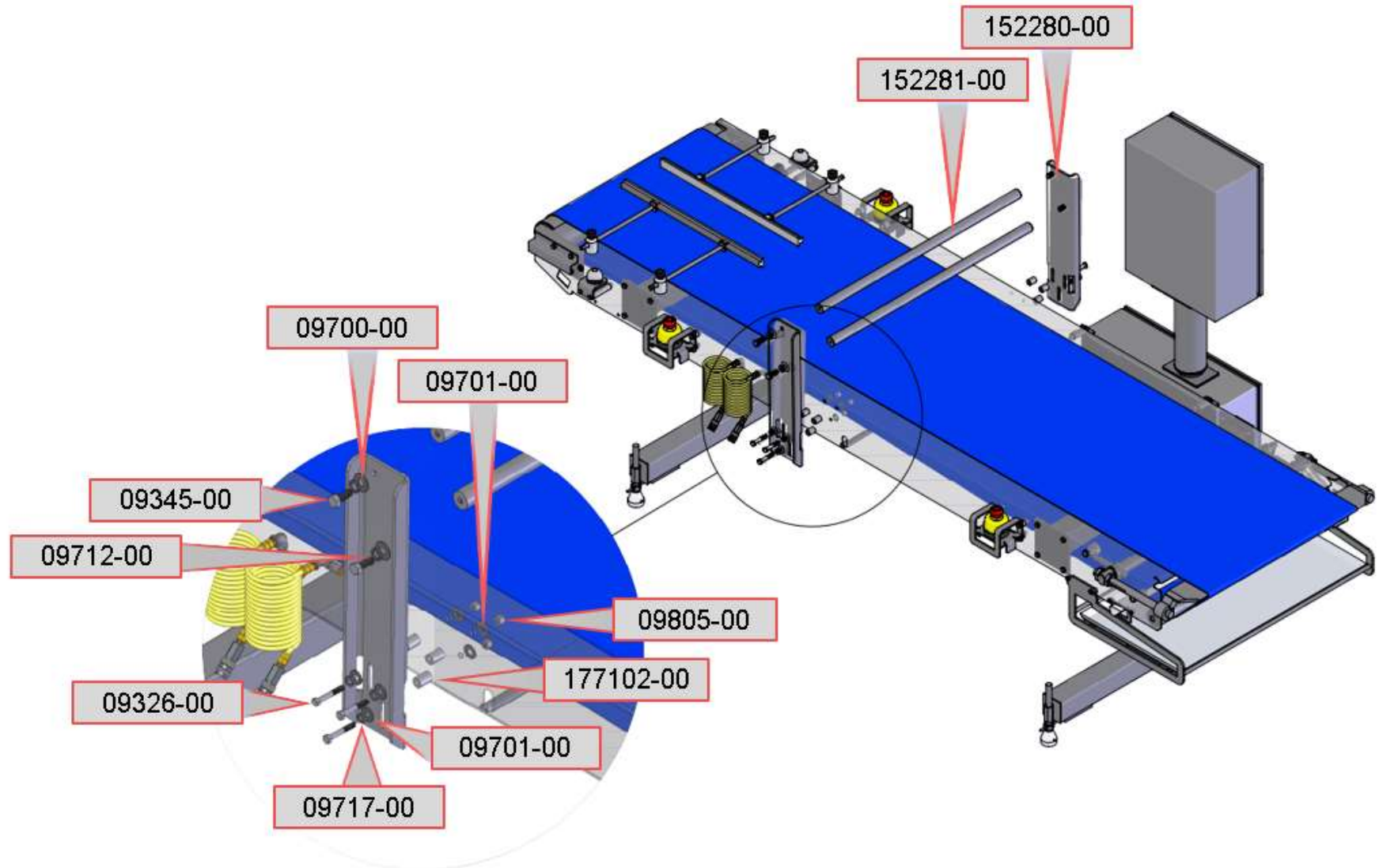

Part Number	Description
09326-00	FAST HEX CAP 3/8-16 X 2-1/4
09345-00	FAST HEX CAP 1/2-13 X 1-1/4
09700-00	WASHER FLAT 1/2
09701-00	WASHER FLAT 3/8
09712-00	WASHER LOCK 1/2
09717-00	WASHER LOCK 3/8
09805-00	FAST NUT NYLOC 3/8
152280-00	BRACKET SRV NZL BRG RH
152281-00	SHAFT 1.250OD 34.625L
177102-00	SPACER 0.75OD 0.38ID 1L S/S

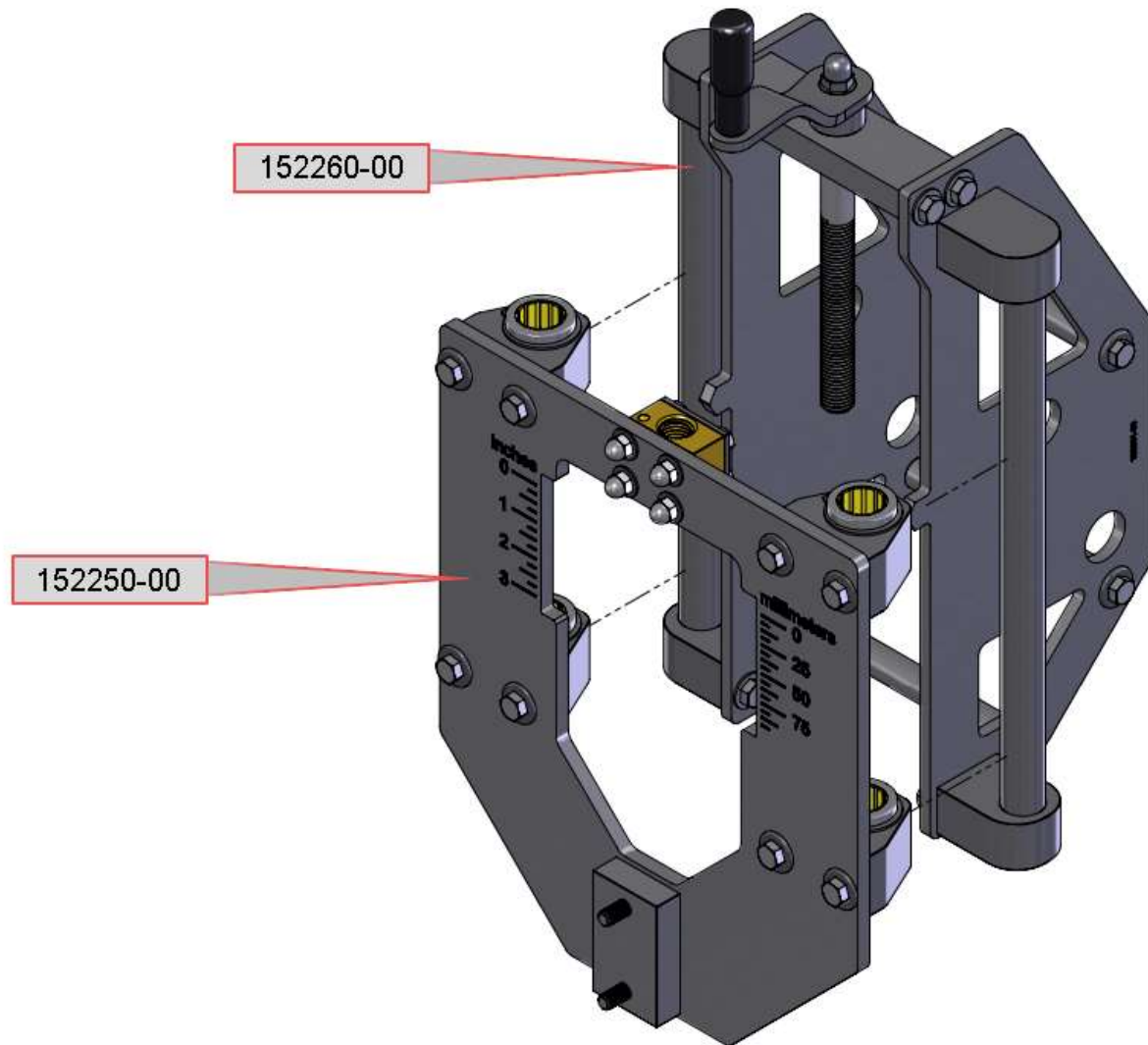

Part Number	Description
152250-00	SUBASS SRV NZL LIFT MECH
152260-00	SUBASS SRV MID NZL HEIGHT ADJ BRG

152260-00

Lift Mechanism

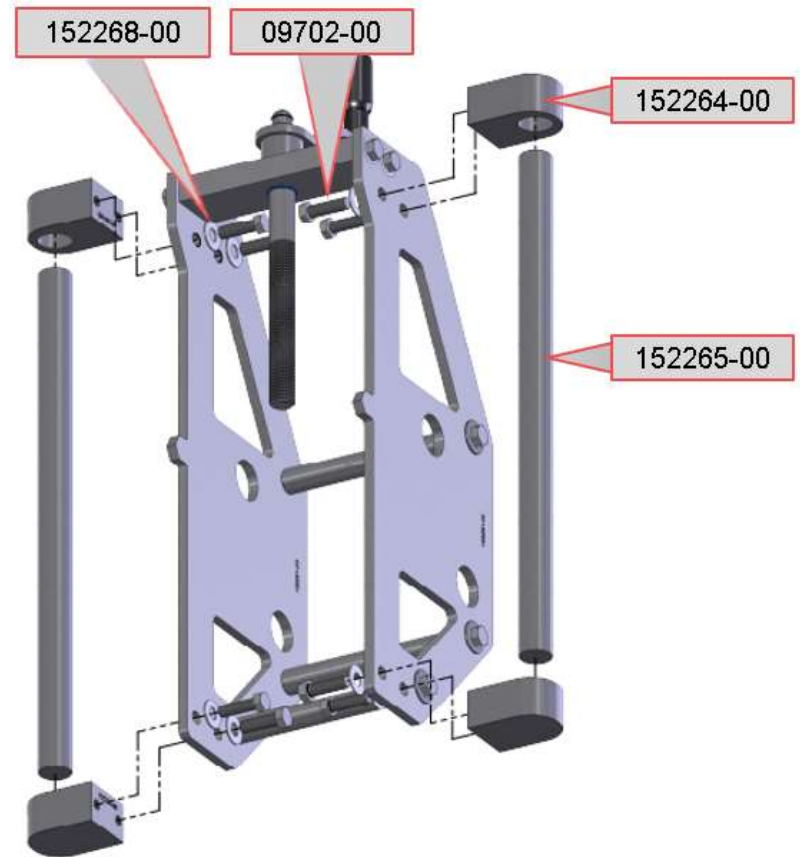
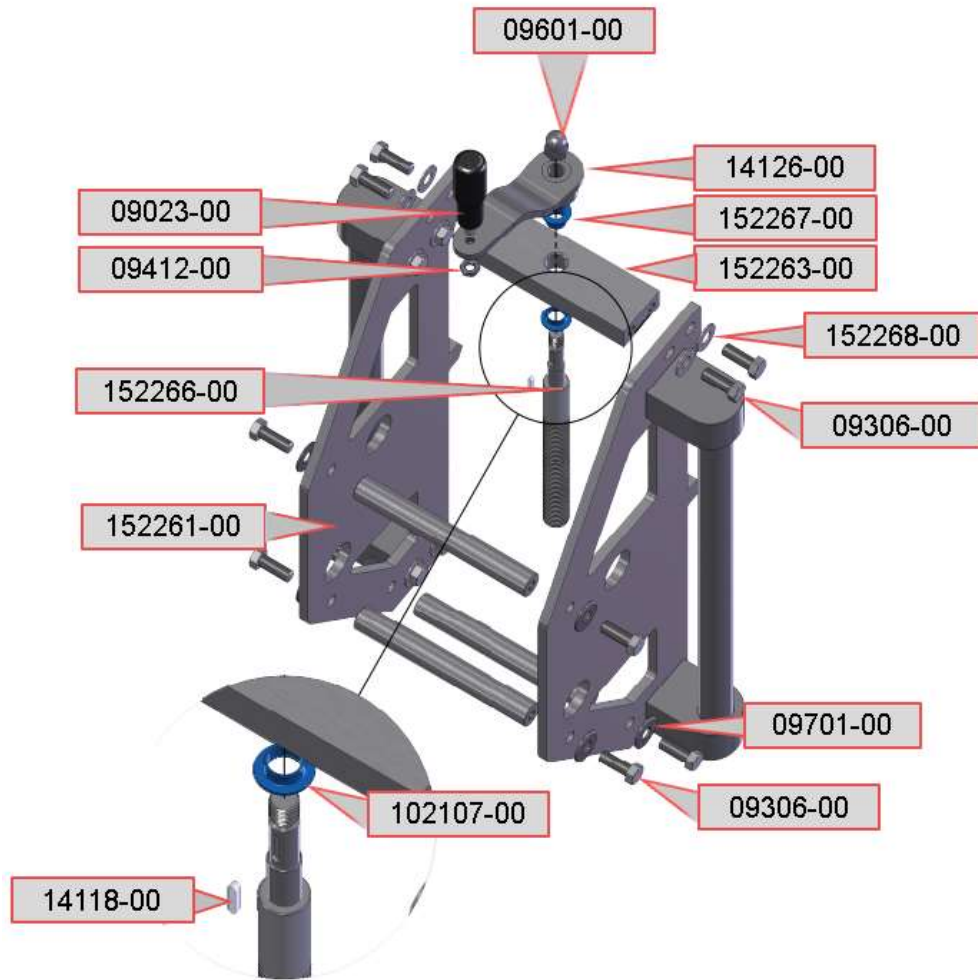

Part Number	Description
09023-00	FAST SKT CAP 3/8-16 X 1
09306-00	FAST HEX CAP 3/8-16 X 1
09412-00	FAST NUT NYLOC M8-1.25
09601-00	FAST NUT ACORN 7/16-20
09701-00	WASHER FLAT 3/8
09702-00	WASHER FLAT 5/16
102107-00	BUSH .594OD .5ID .375L .875FD
14118-00	KEY 1/8 X 1/8 X 5/8
14126-00	SUBASS HAND CRANK
152261-00	BRACKET SRV MID NZL HEIGHT ADJ STD
152263-00	BRACKET HEIGHT ADJ CRK SRV MID NZL
152264-00	BLOCK 1ID LINEAR GUIDE SS
152265-00	SHAFT 1.000OD 16.00L
152266-00	SHAFT 3/4-10 ACME 9.1L SRV NZL ADJ
152267-00	BUSH .594OD .5ID .5L .875FD
152268-00	WASHER .406ID .75OD .05T

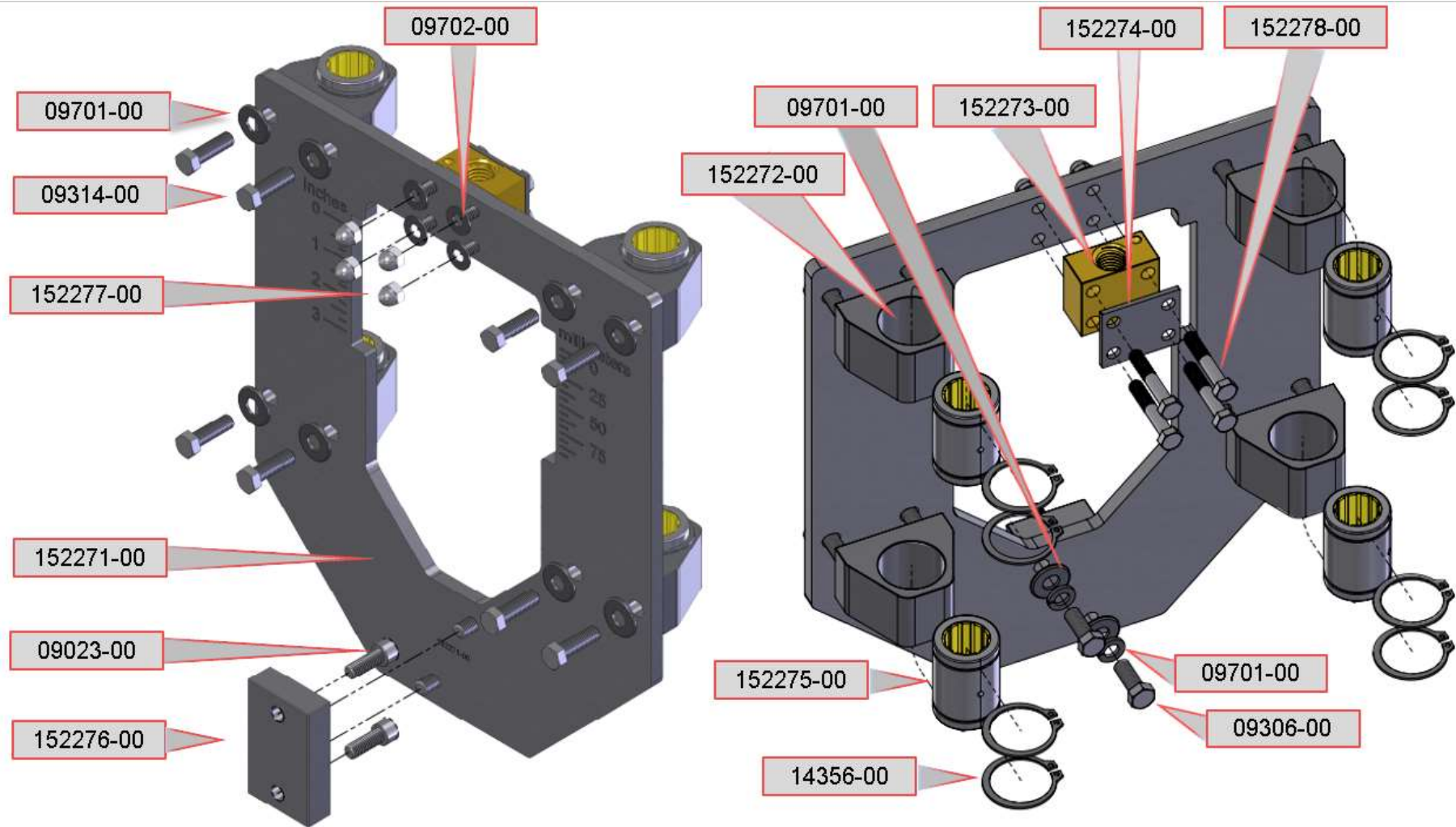

=

Part Number	Description
09023-00	FAST SKT CAP 3/8-16 X 1
09306-00	FAST HEX CAP 3/8-16 X 1
09314-00	FAST HEX CAP 3/8-16 X 1-1/4
09701-00	WASHER FLAT 3/8
09702-00	WASHER FLAT 5/16
14356-00	RING RET EXT 1.468OD LINEAR BEARING
152271-00	PLATE SRV MID NZL MOUNT
152272-00	BLOCK 1.5625ID LINEAR GUIDE SS
152273-00	BLOCK 3/4-10 ACME BRIDGE
152274-00	PLATE SPACER SRV NZL BRG
152275-00	BEARING LINEAR 1.5625OD 1ID 2.25W
152276-00	PLATE SRV NZL BRG HOLDER
152277-00	FAST NUT ACORN 5/16-18
152278-00	FAST HEX CAP 1/2-13 X 1-7/8

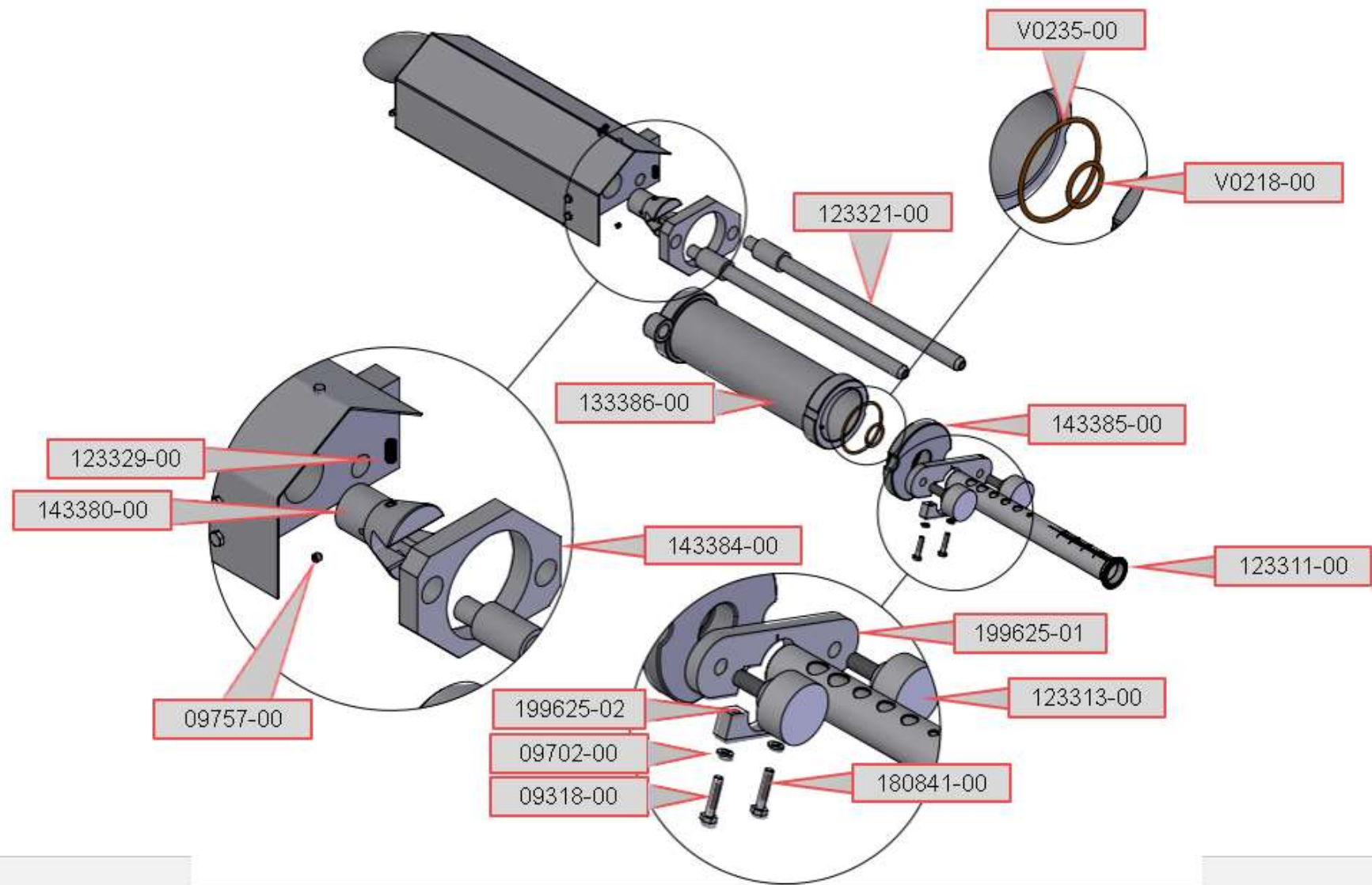

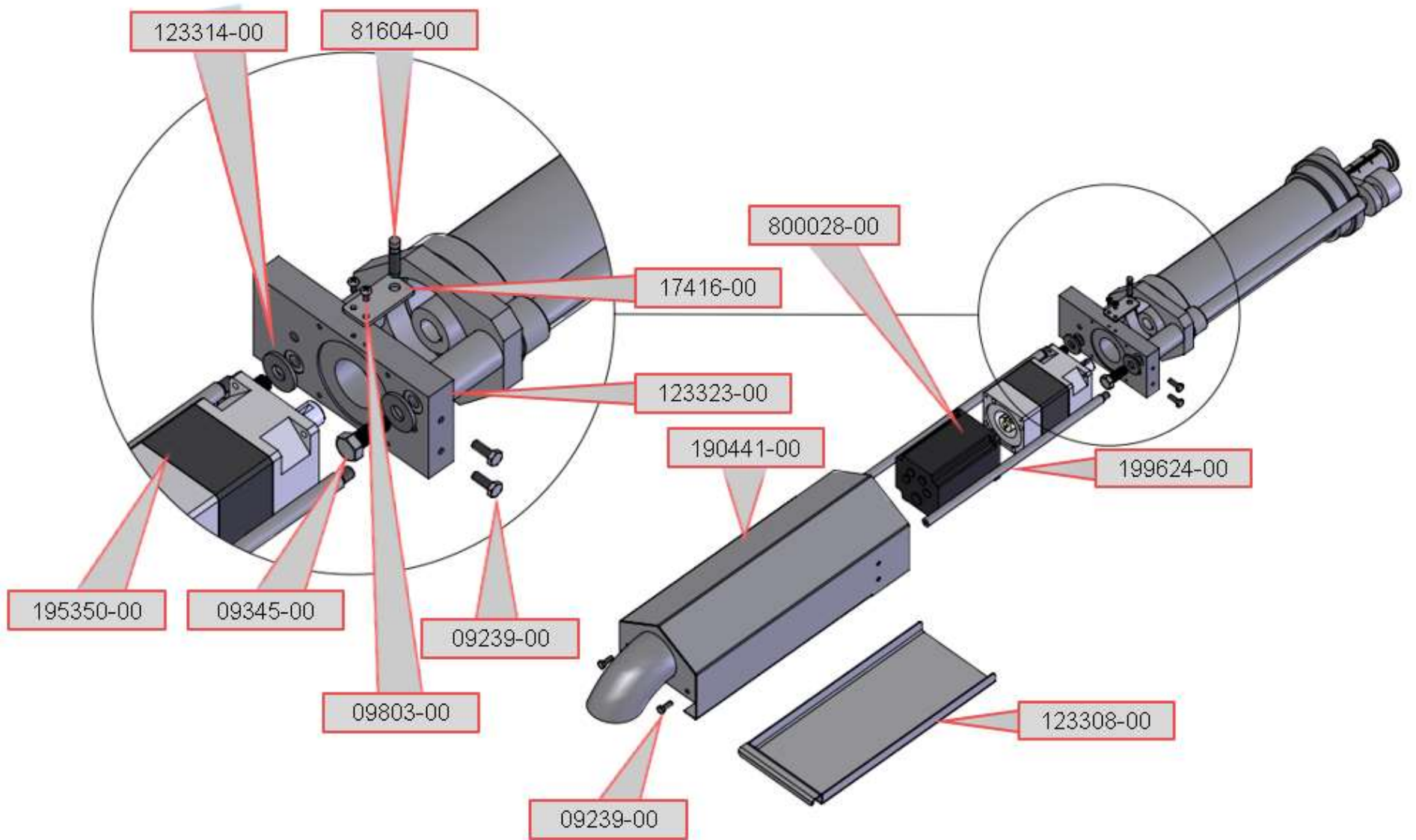

Part Number	Description
09239-00	FAST HEX CAP 1/4-20 X 3/4
09318-00	FAST HEX CAP 1/4-20 X 1-1/4
09345-00	FAST HEX CAP 1/2-13 X 1-1/4
09702-00	WASHER FLAT 5/16
09757-00	FAST SET SCREW 1/4-20 X 1/4
09803-00	FAST NUT NYLOC 1/4-20
123308-00	COVER TRAY BOTTOM SERVO NOZZLE
123311-00	PIPE WELD INLET SERVO SPREADER
123313-00	WASHER MC 0.51ID 1.25OD 0.13T
123314-00	WASHER MC 0.51ID 1.25OD 0.13T
123321-00	ROD SUPPORT SERVO SPREADER
123323-00	PLATE SERVO SPREADER MOUNT
123329-00	FAST SET SCREW 5/16-18 X 3/4
133386-00	SUBCOMP NOZZLE BODY SERVO .219 WELD
143380-00	ADAPTER SERVO T NOZZLE LH
143384-00	PLATE SERVO SPREADER MOUNT
143385-00	CAP ROUND 3.4 PIPE SERVO NOZZLE
17416-00	BRACKET SENSOR MOUNT
180841-00	FAST NUT JAM 1-8
190441-00	COVER MOTOR SERVO SPREADER NOZZLE
195350-00	GEARBOX 22:1 SIZE 34
199624-00	ROD 14L 0.5OD 3/8-16 1/4-20 ENDS
199625-01	PLATE CLAMP TOP SERVO SPR NZL
199625-02	PLATE CLAMP BTM SERVO SPR NZL
800028-00	MOTOR SERVO ANIMATICS NEMA34 IP65
81604-00	SENSOR PROXIMITY INDUCT. M8 P&F
V0218-00	O-RING FOOD SERVICE 218
V0235-00	O-RING FOOD SERVICE 235

## Control System Spare Parts

Item number.	Part number.	Description
1	81482-00	FUSE TIME DELAY 10A CLASS CC R
2	80043-00	FUSE 5 AMP TIMED-DELAY 600V
3	81473-00	FUSE 3A TIME DELAY FNQ
4	81470-00	FUSE 1A TIME DELAY FNQ
5	81282-00	FUSE 10A GLASS
6	80036-00	FUSE 5 AMP
7	80035-00	FUSE 2 AMP

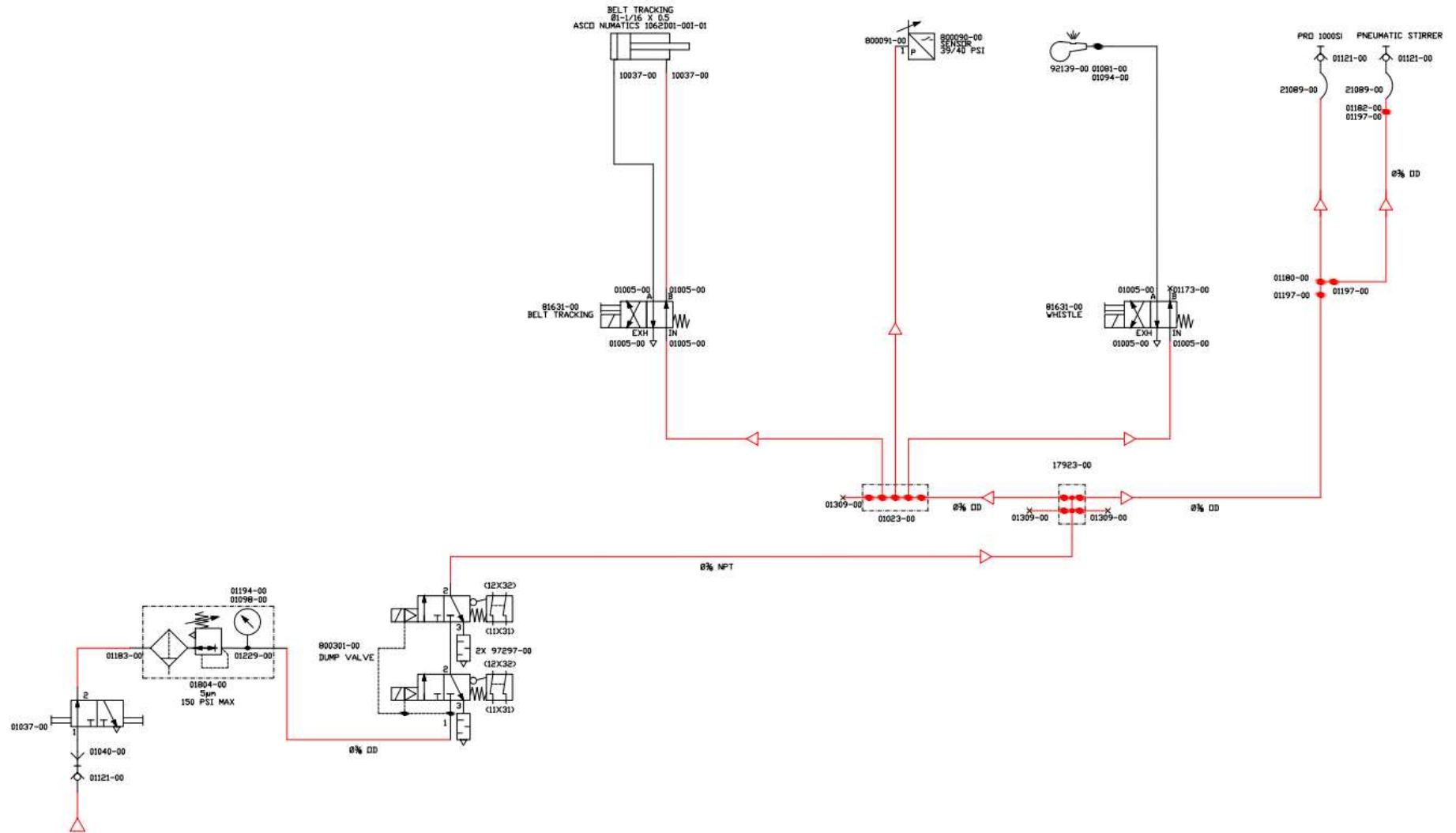

# Pneumatic Schematics



## Pneumatic Components

Description	Image	Part number
Air Filter and Regulator		113329-00
2 Way Valve		81631-00
Pneumatic Pressure Sensors		80419-00
Manifold		01023-00
Whistle		92139-00
Manifold		17923-00

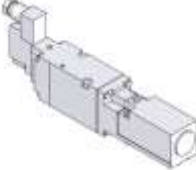
Table for all customer specific projects.

Description	Image	Part number
Soft Start Valve compliant with CAT 3		800301-00
Air Actuator (belt tracking)		

## **Electrical Schematics**

Please refer to the PDF documents on the CD supplied with your machine.